



# **Engineering Alliance**

Custom Air Systems Engineering



## Custom Air Systems Engineering

PFD-01 - STEAM MUA UNIT

PFD-02 - HVAC SYSTEM

PFD-03 - HVAC SYSTEM WITH PRESSURIZATION FAN

PFD-04 - ELECTRICAL ROOM HVAC

PFD-05 - PULPER MIST CONTAINMENT SYSTEM

PFD-06 - VENTURI SCRUBBER SYSTEM

PFD-07 - VENTURI SCRUBBER WITH EXTERNAL RESERVOIR

PFD-08 - BROKE SEPARATOR

PFD-09 - NYE TRAY WET SCRUBBER SYSTEM

PFD-10 - SCRUBBING WATER SYSTEM

PFD-11 - MIST CONTAINMENT SYSTEM

PFD-12 - WET SCRUBBING EXHAUST SYSTEM WITH AIR CURTAIN SUPPLY

PFD-13 - HIGH PRESSURE AIR SUPPLY SYSTEM

PFD-14 - DIRECT AIR TO WATER HEAT RECOVERY SYSTEM

PFD-15 - INDIRECT AIR TO LIQUID HEAT RECOVERY SYSTEM

PFD-16 - COATING CONTAINMENT SYSTEM

PFD-17 - WEB CLEANER SYSTEM - DRY

PFD-18 - WEB CLEANER SYSTEM – WITH WET SCRUBBER

PFD-19 - TAIL THREADING REEL DRUM VACUUM

PFD-20 - TRIM CONVEYING SYSTEM – INJECTOR TYPE

PFD-21 - TRIM CONVEYING SYSTEM – CHOPPER TYPE

PFD-22 - TRIM CONVEYING SYSTEM – CHOPPER TYPE

PFD-23 - TRIM CONVEYING SYSTEM – WET SEPARATOR TYPE

PFD-24 - TRIM CONVEYING SYSTEM – WET SYSTEM

PFD-25 - AIR CURTAIN SUPPLY SYSTEM

PFD-26 - TRUCK DOOR AIR CURTAINS

PFD-27 - PNEUMATIC FEED SYSTEM

PFD-28 - SOLIDS CONVEYING SYSTEM

PFD-29 - BAGHOUSE SYSTEM

PFD-30 - CYCLONE AND BAGHOUSE SYSTEMS

PFD-31 - TISSUE PNEUMATIC CONVEYING SYSTEMS

PFD-32 - INDUSTRIAL VACUUM SYSTEM

# STEAM MUA UNIT

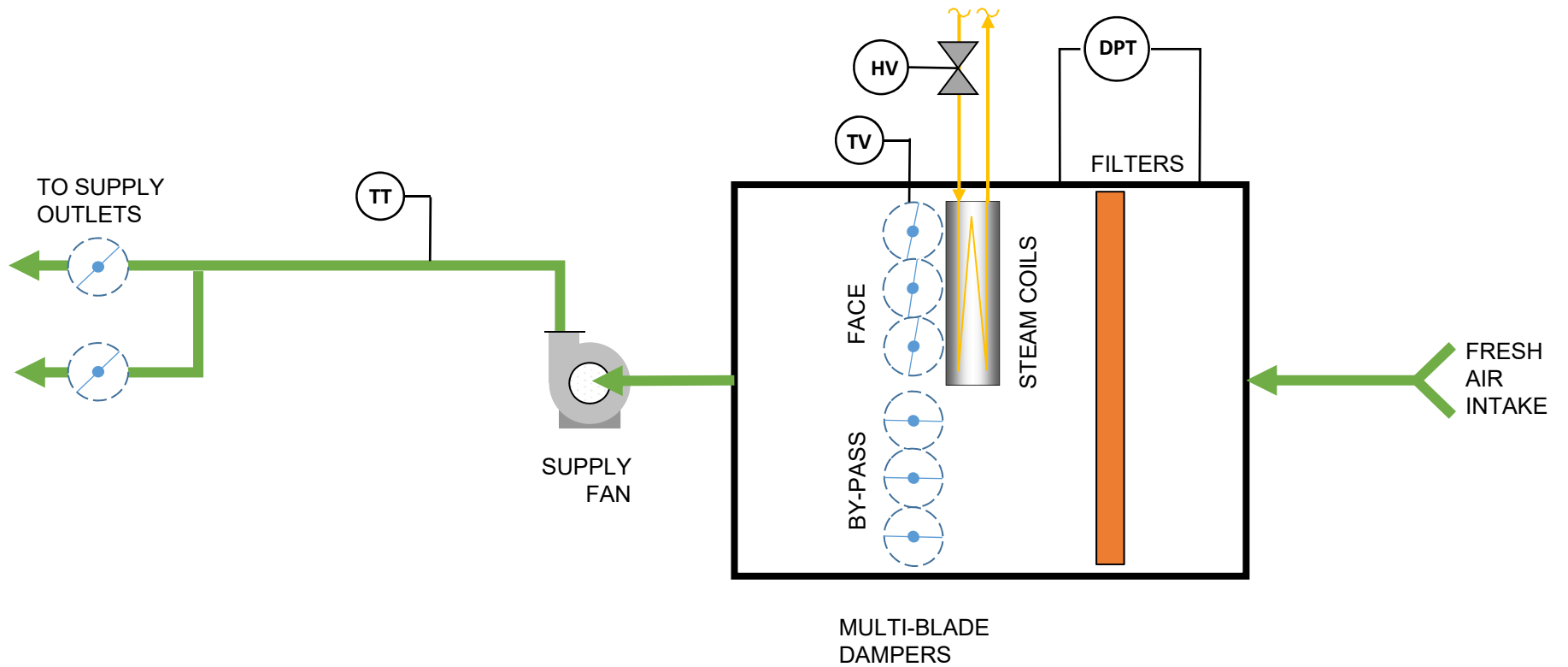

# HVAC SYSTEM

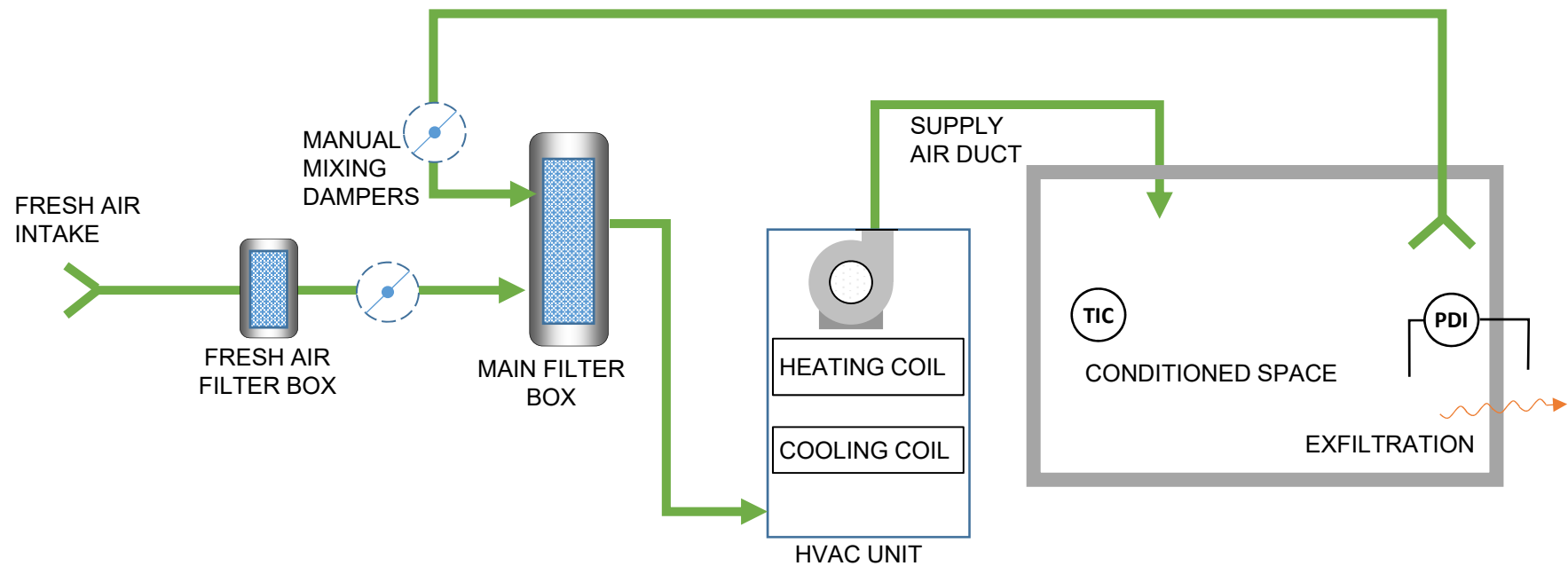

# HVAC SYSTEM WITH PRESSURIZATION FAN

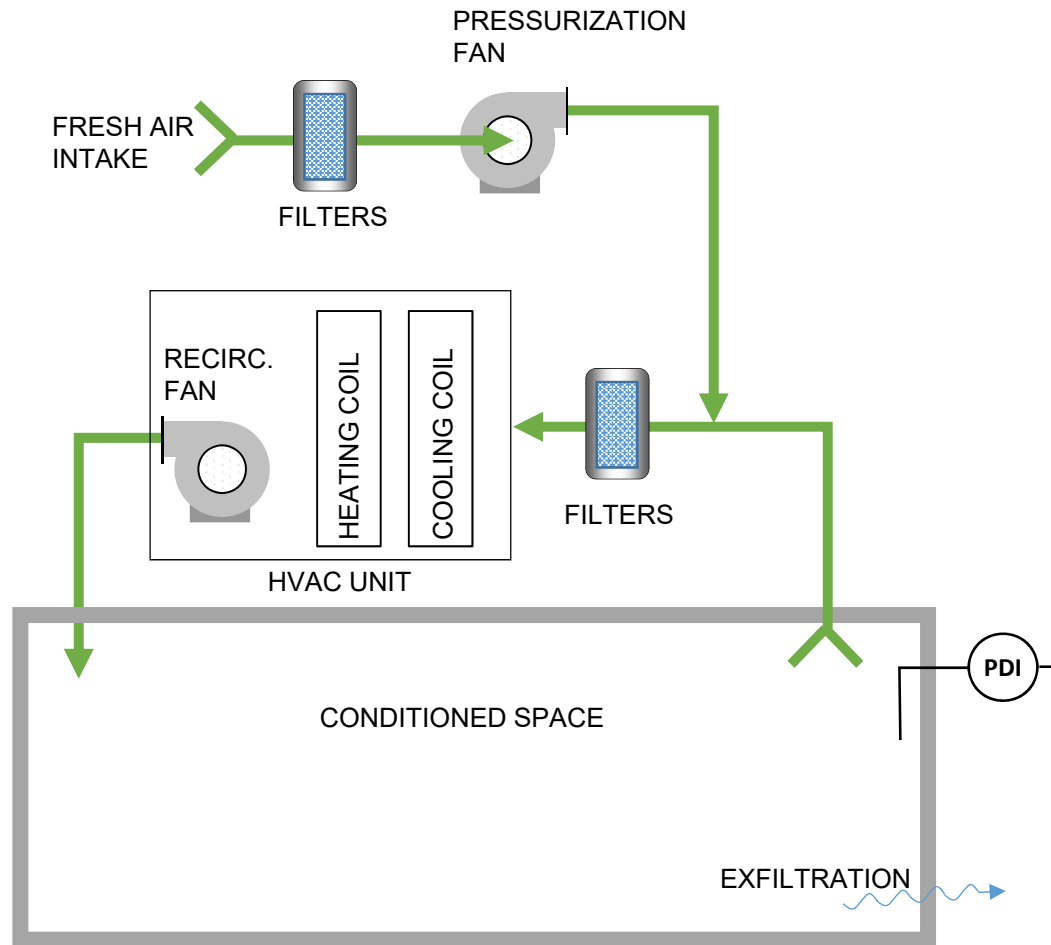

# ELECTRICAL ROOM HVAC

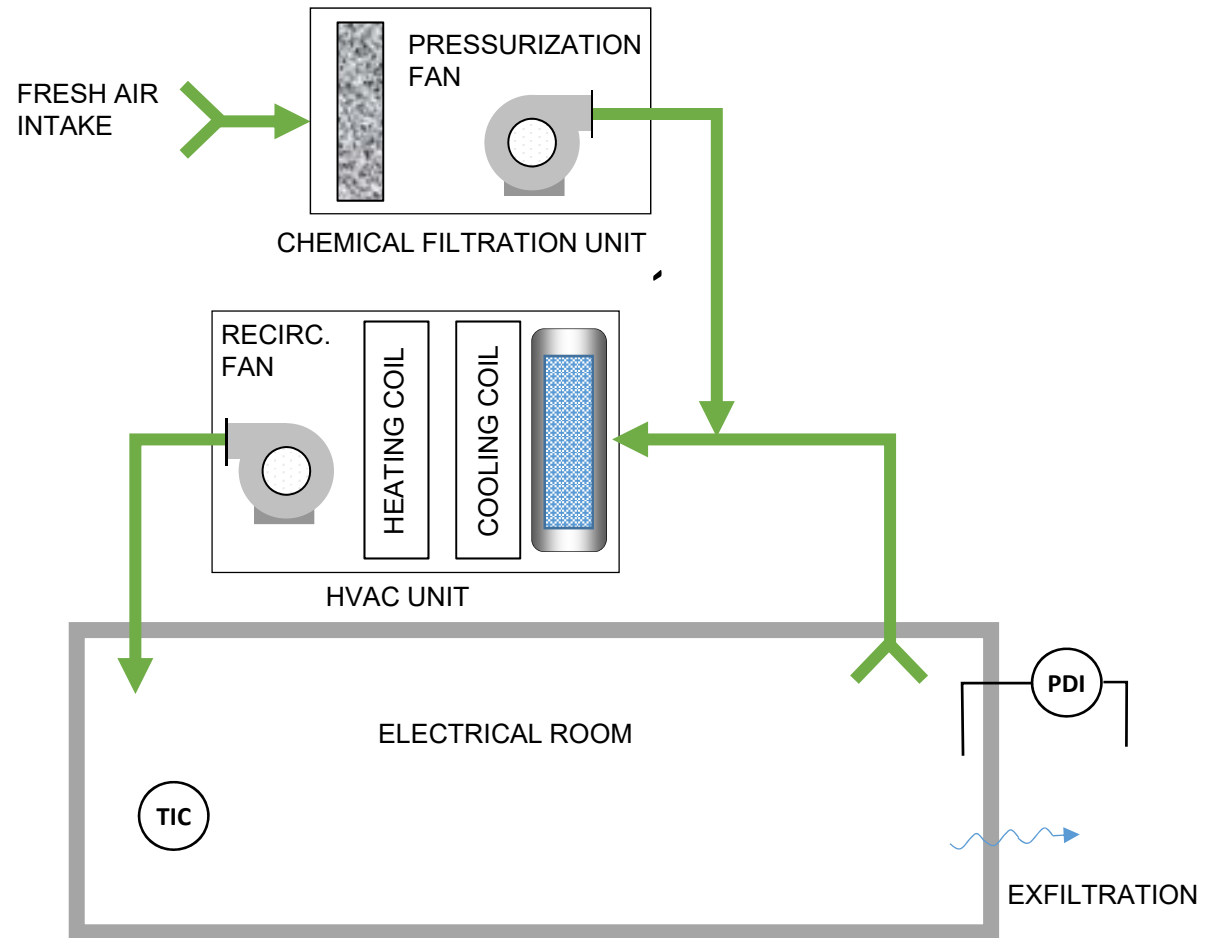

# PULPER MIST CONTAINMENT SYSTEM

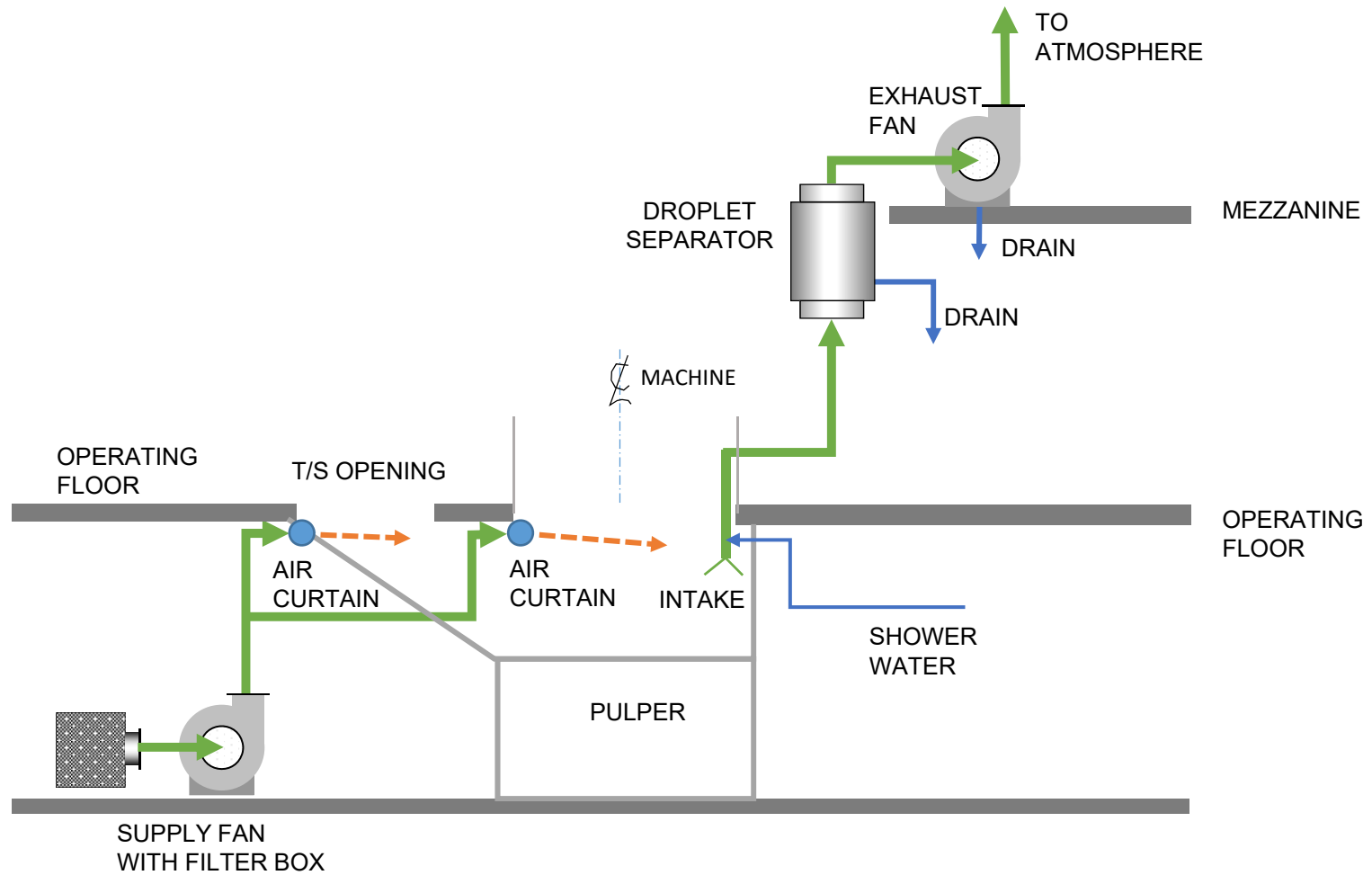

**Engineering  
Alliance**

# VENTURI SCRUBBER SYSTEM

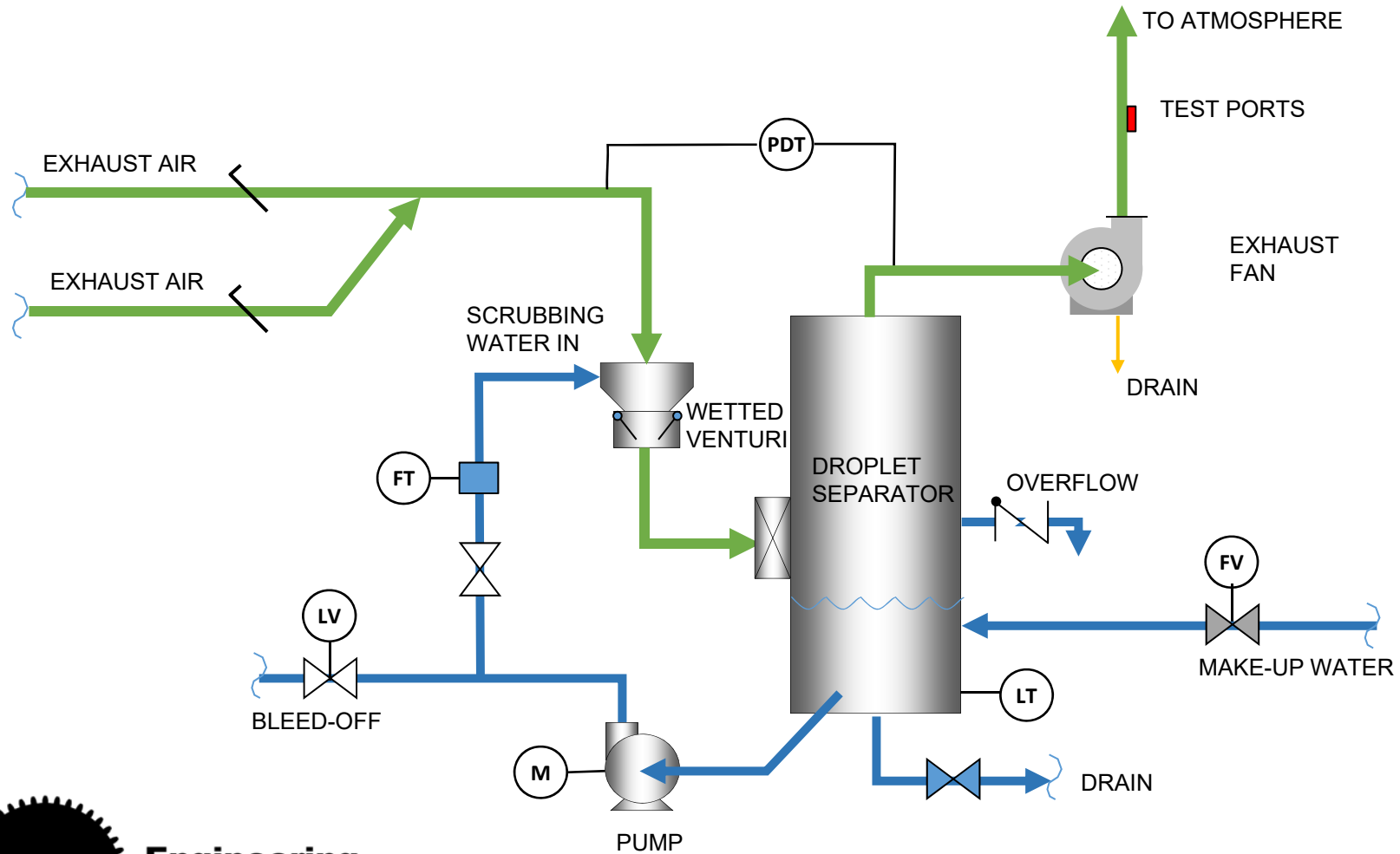



# VENTURI SCRUBBER WITH EXTERNAL RESERVOIR

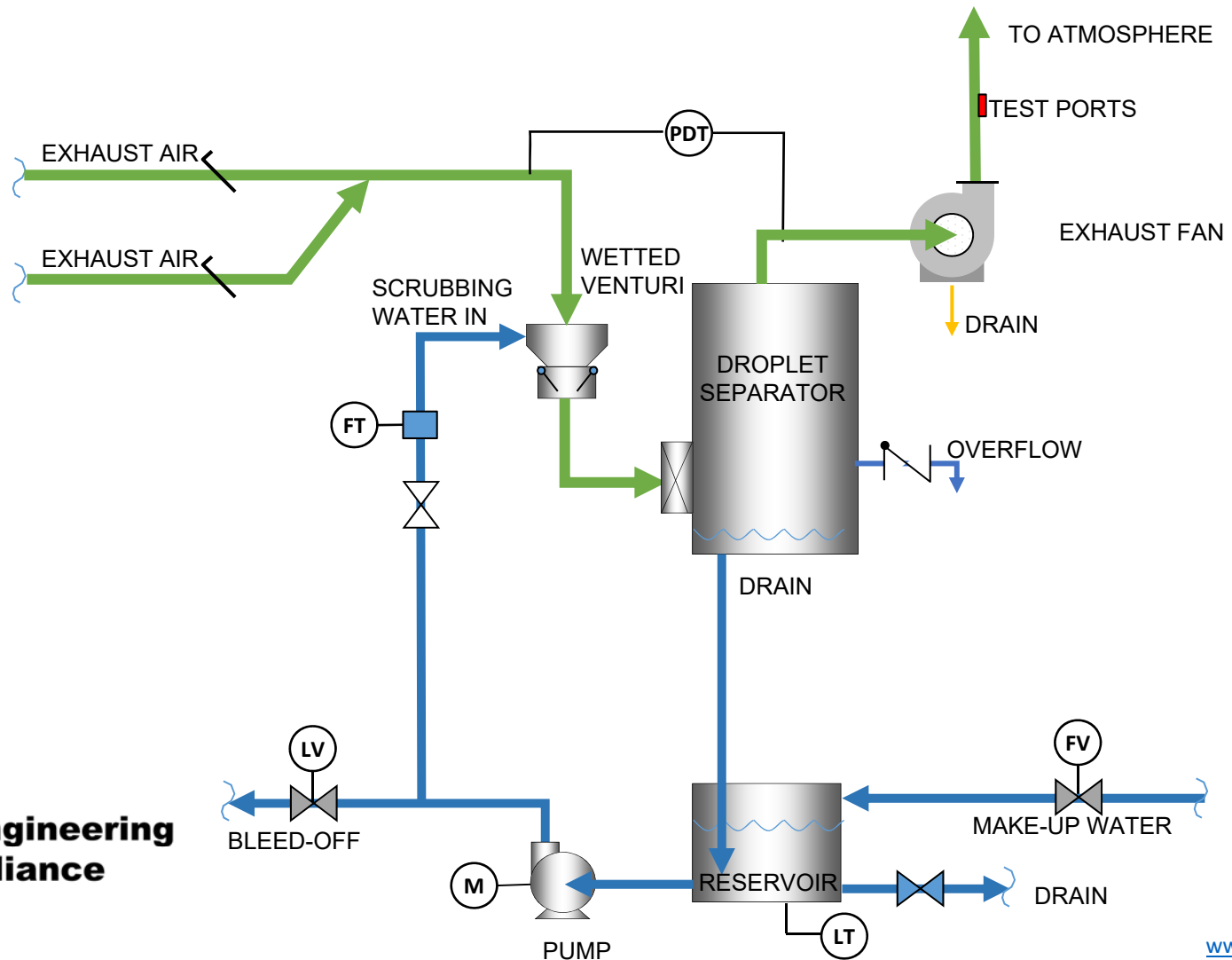

# BROKE SEPARATOR

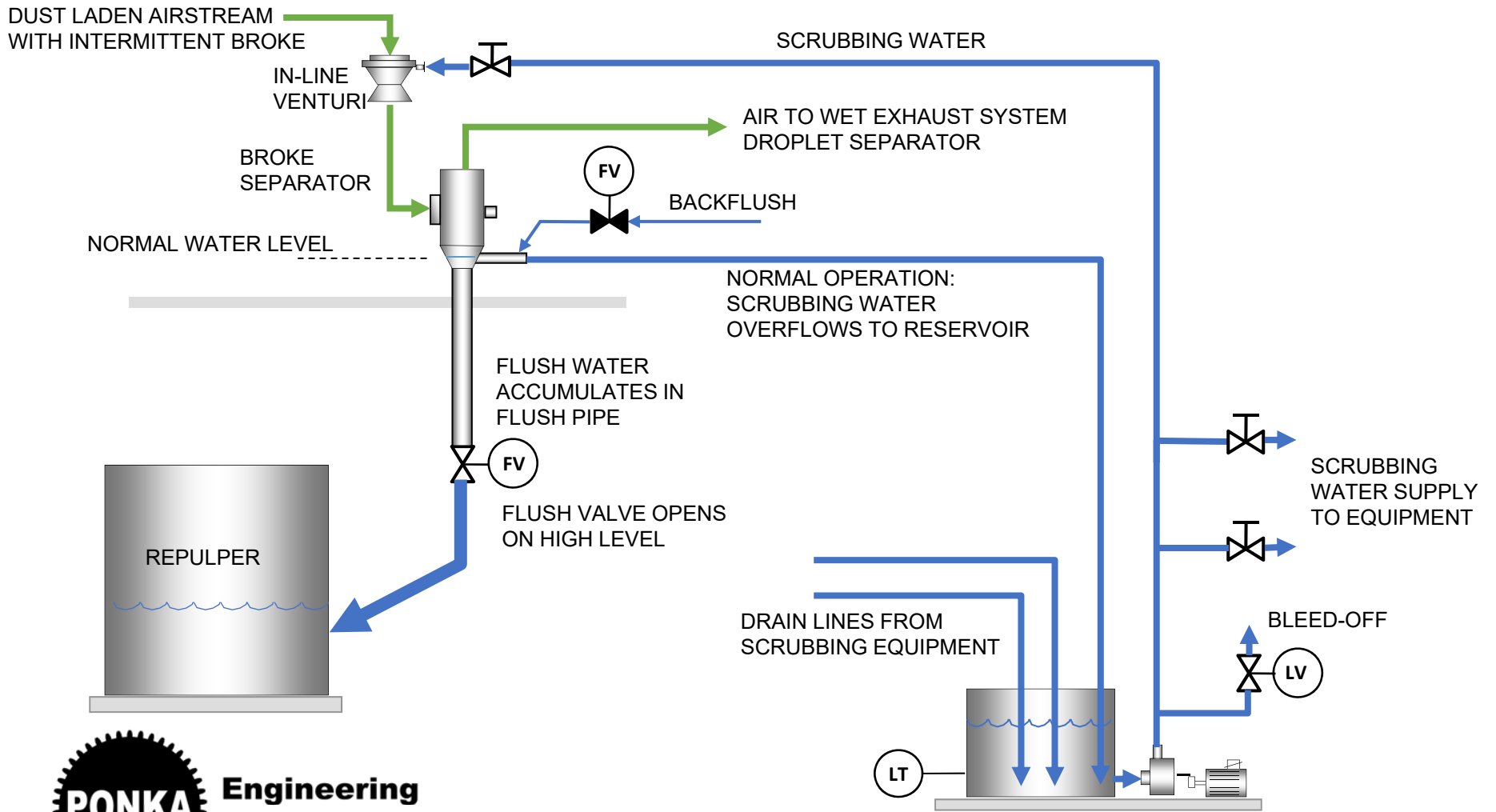

# NYE TRAY WET SCRUBBER SYSTEM

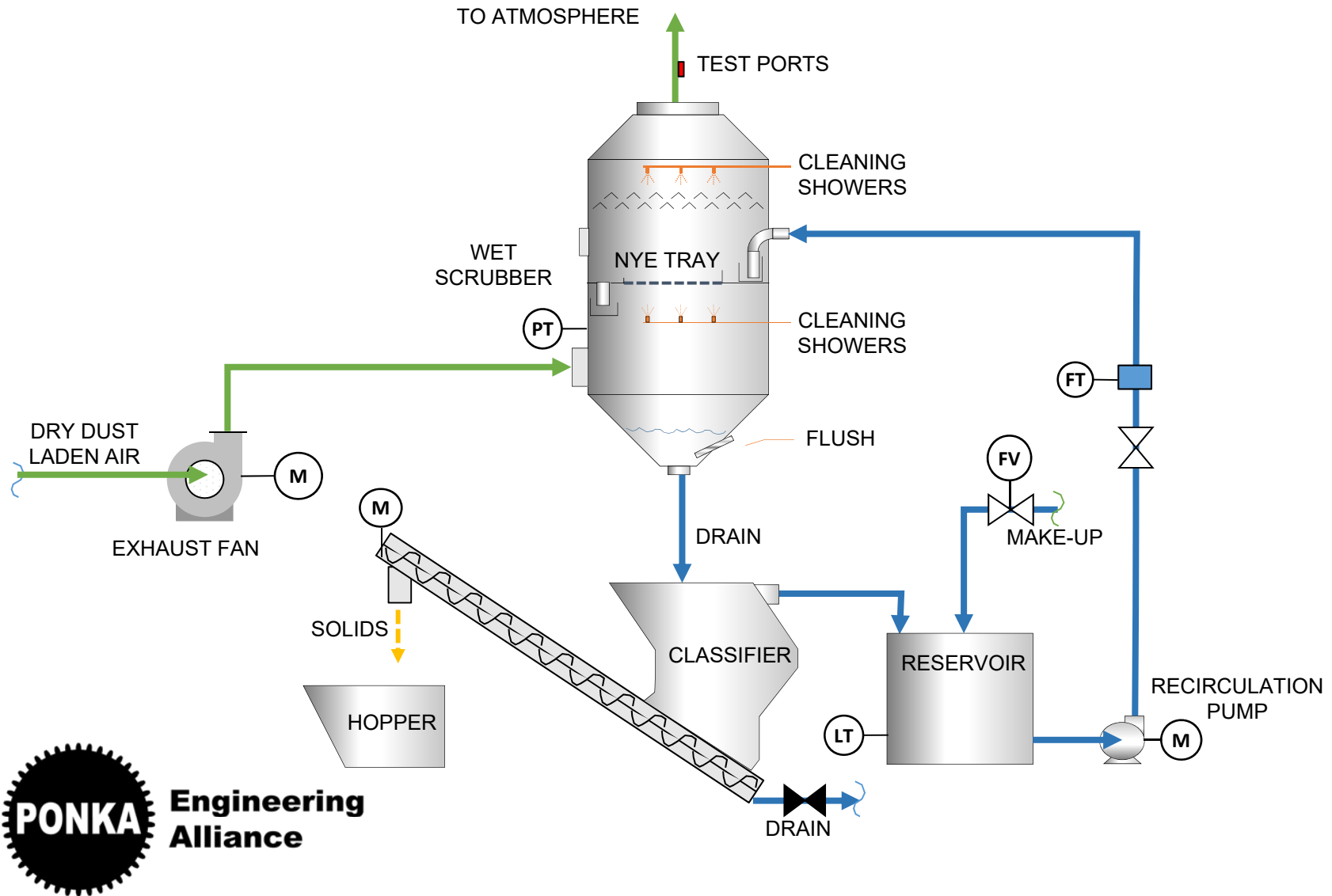

# SCRUBBING WATER SYSTEM

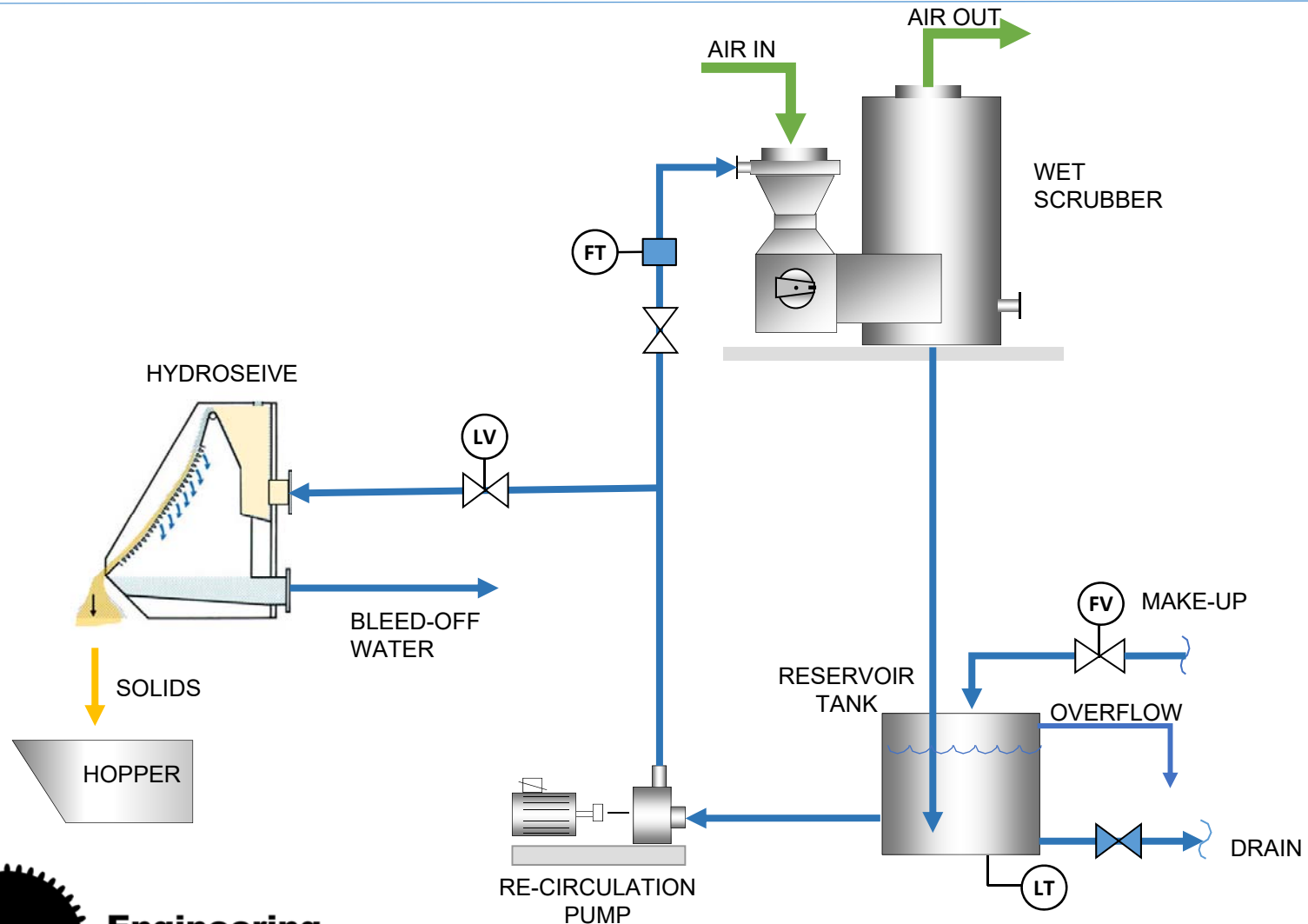

# MIST CONTAINMENT SYSTEM

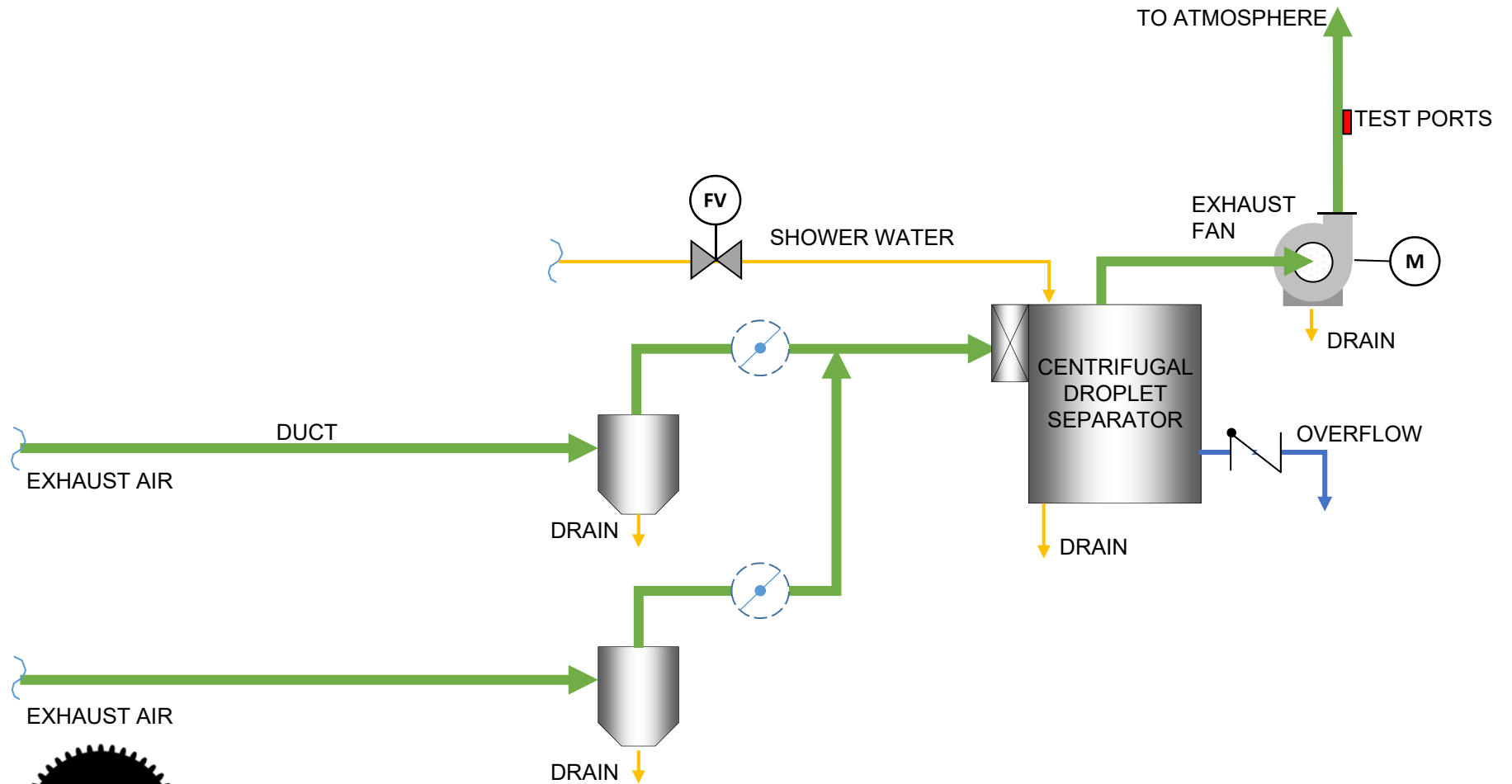

# WET SCRUBBING EXHAUST SYSTEM WITH AIR CURTAIN SUPPLY

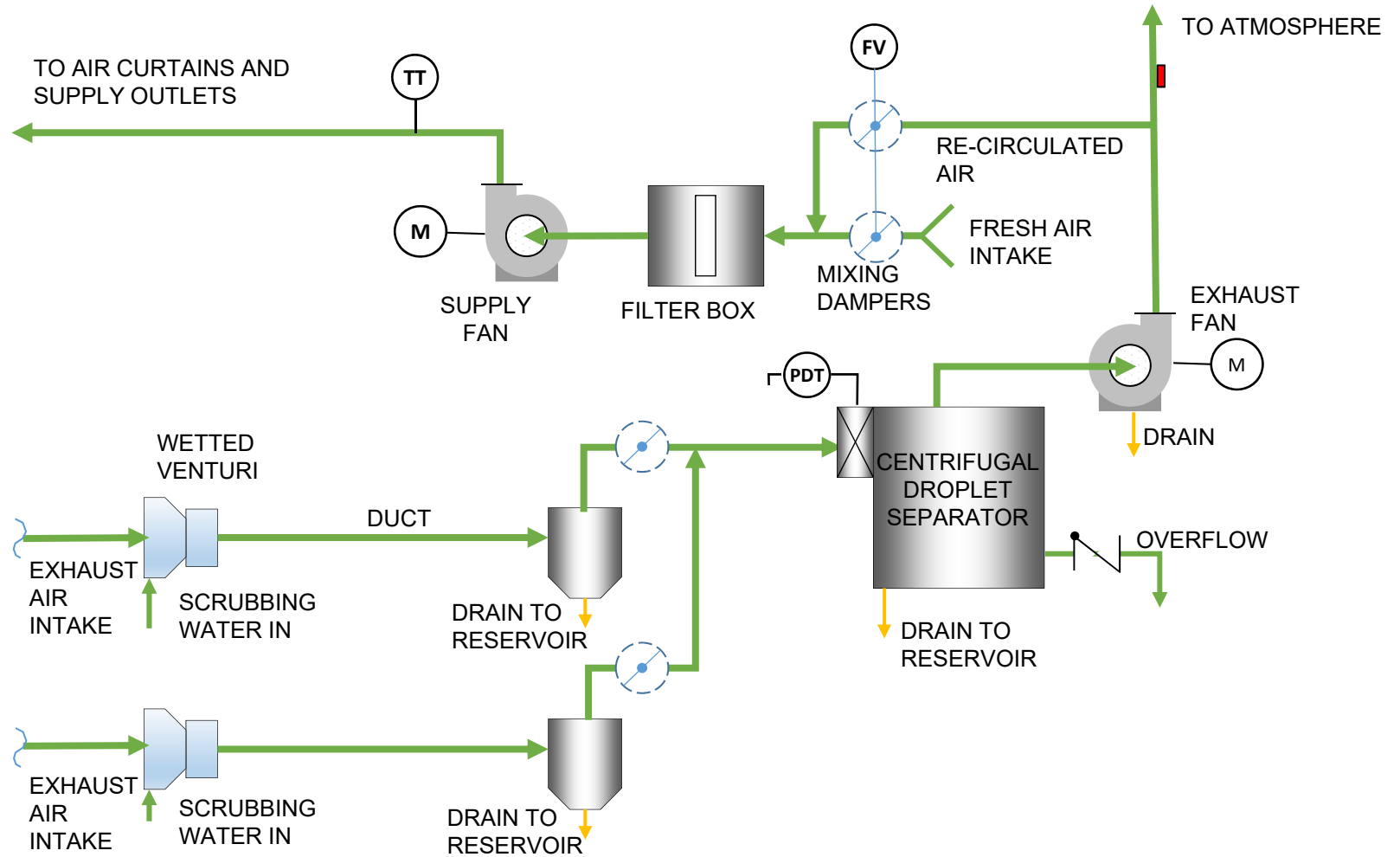

# HIGH PRESSURE AIR SUPPLY SYSTEM

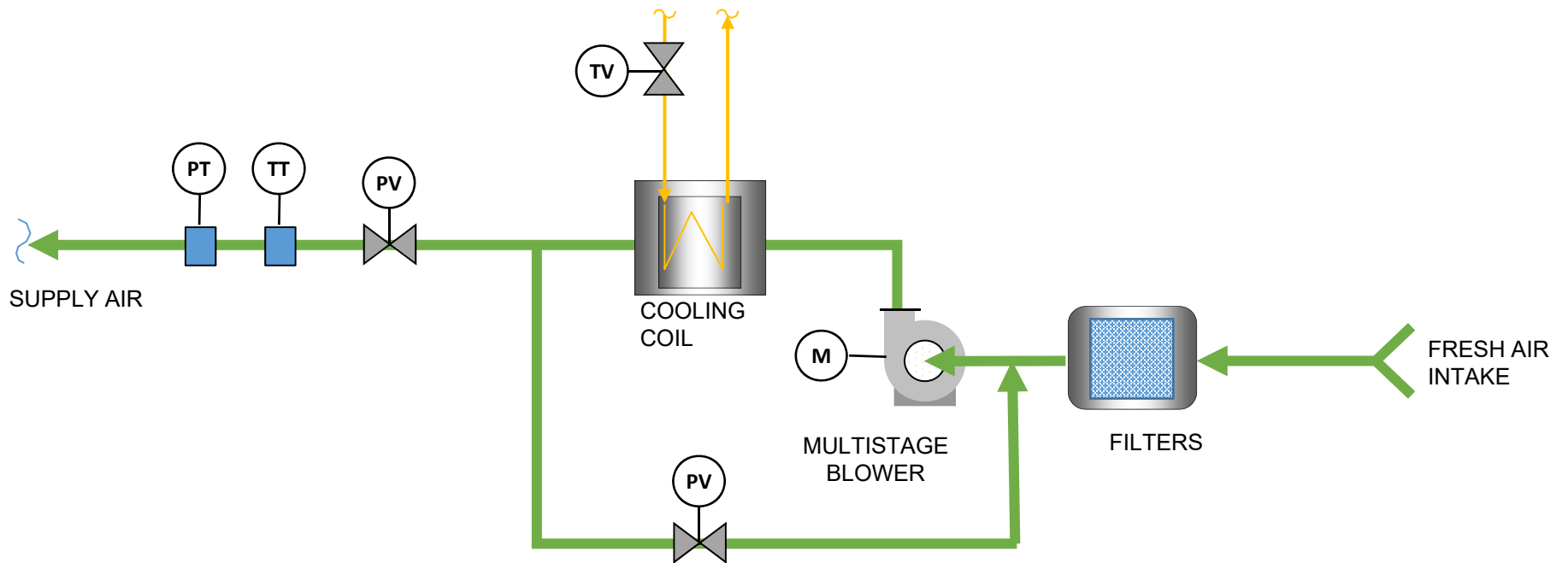

# DIRECT AIR TO WATER HEAT RECOVERY SYSTEM

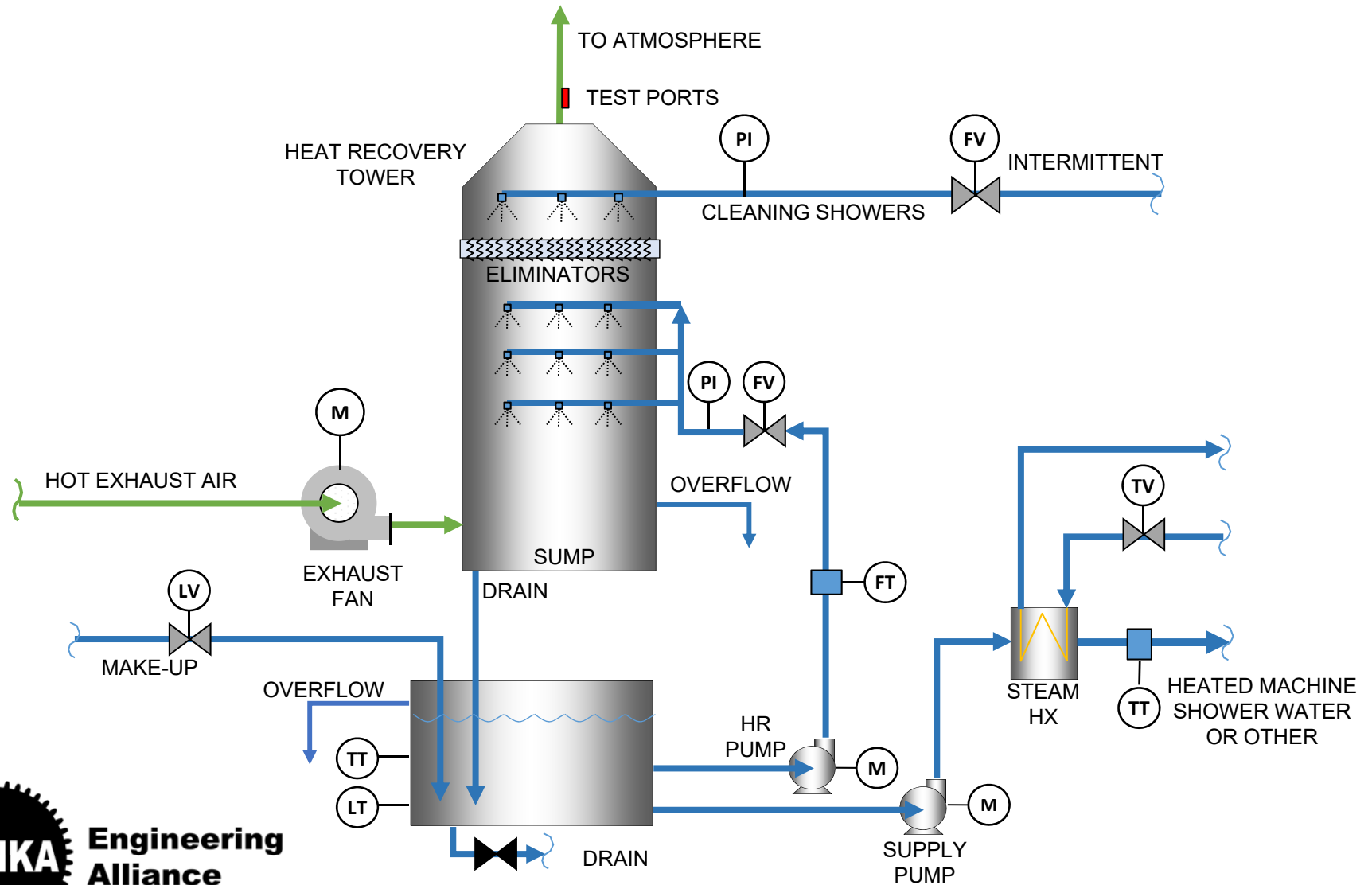



# INDIRECT AIR TO LIQUID HEAT RECOVERY SYSTEM

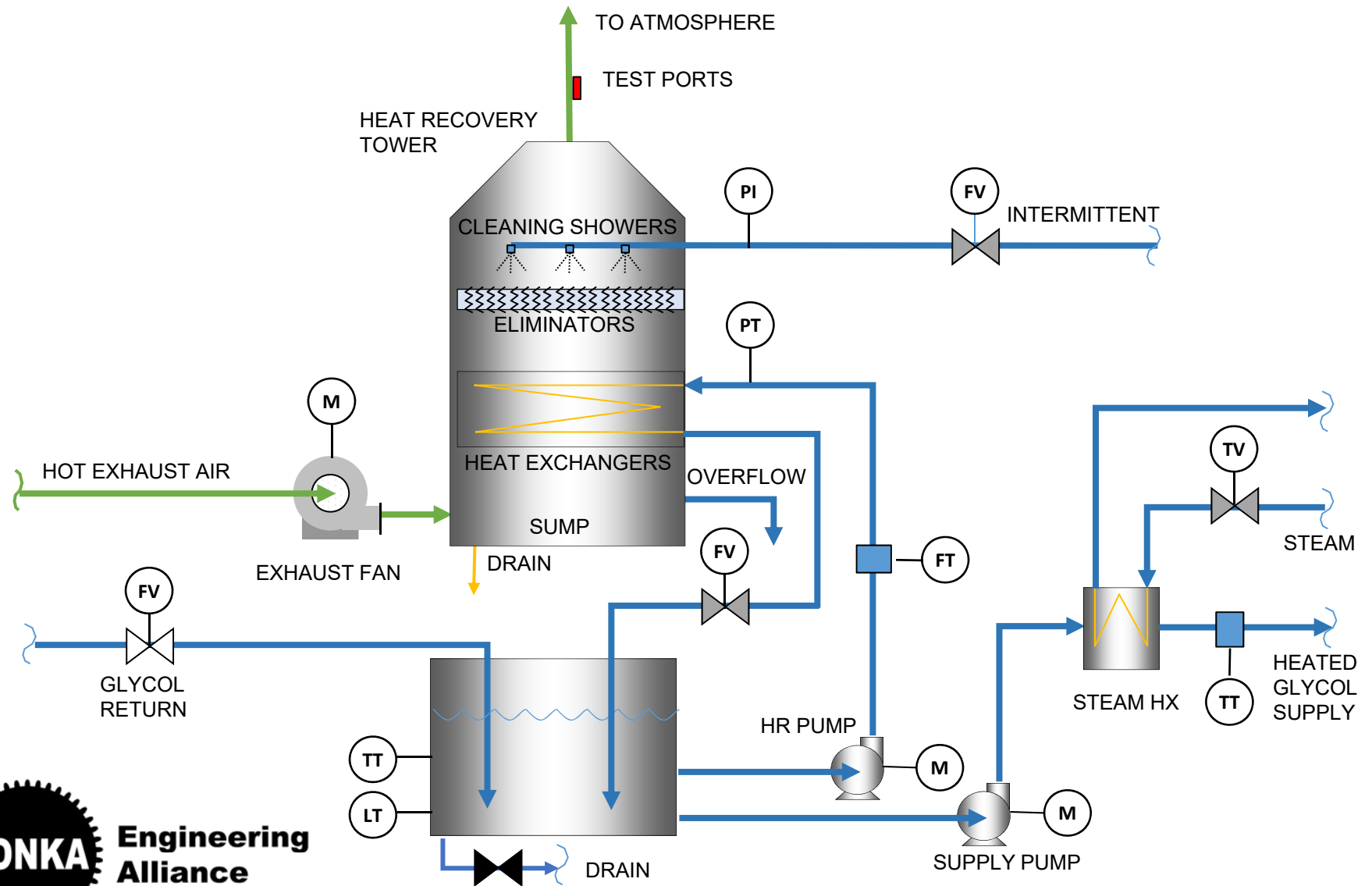

# COATING CONTAINMENT SYSTEM

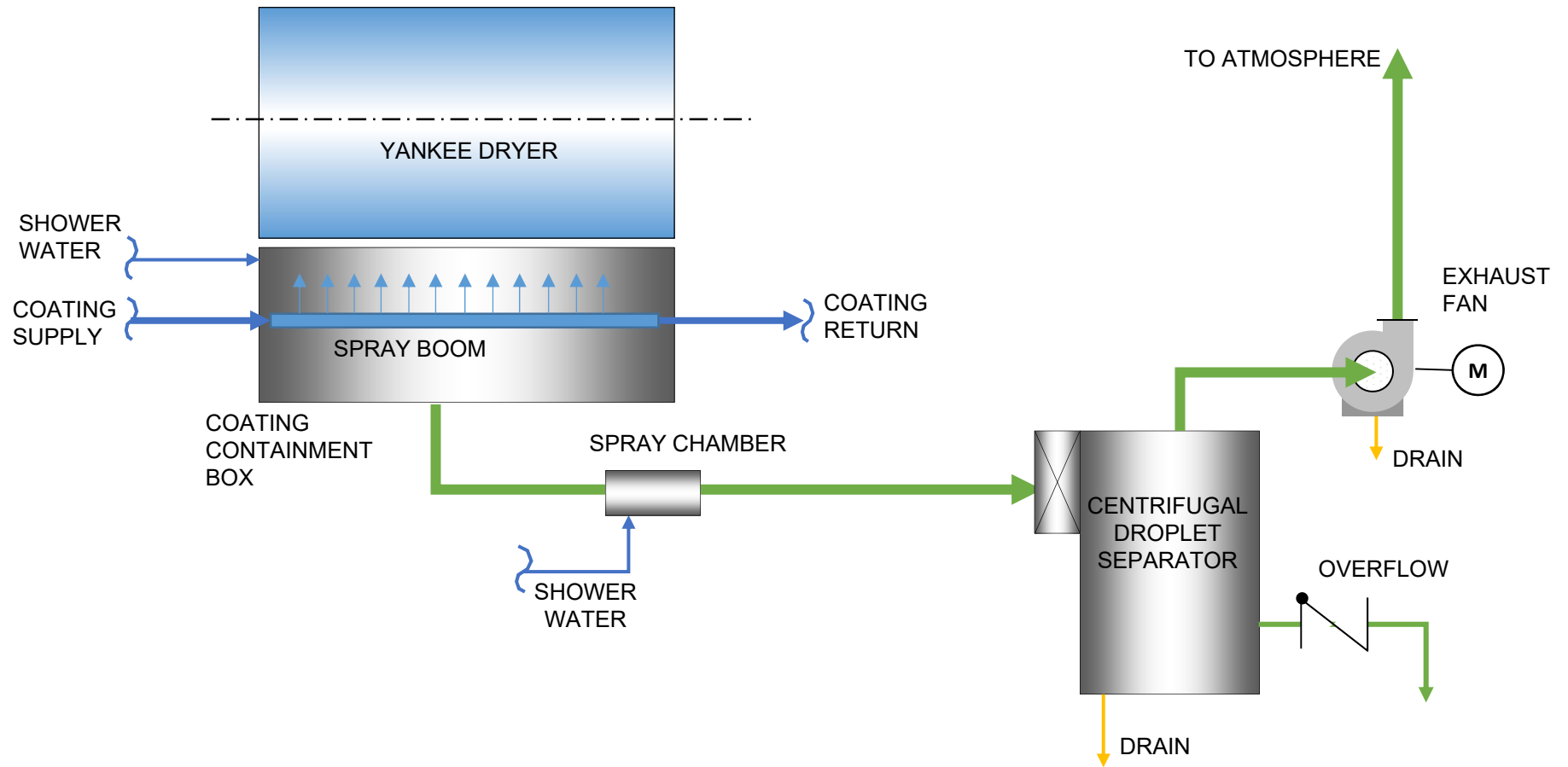

# WEB CLEANER SYSTEM - DRY

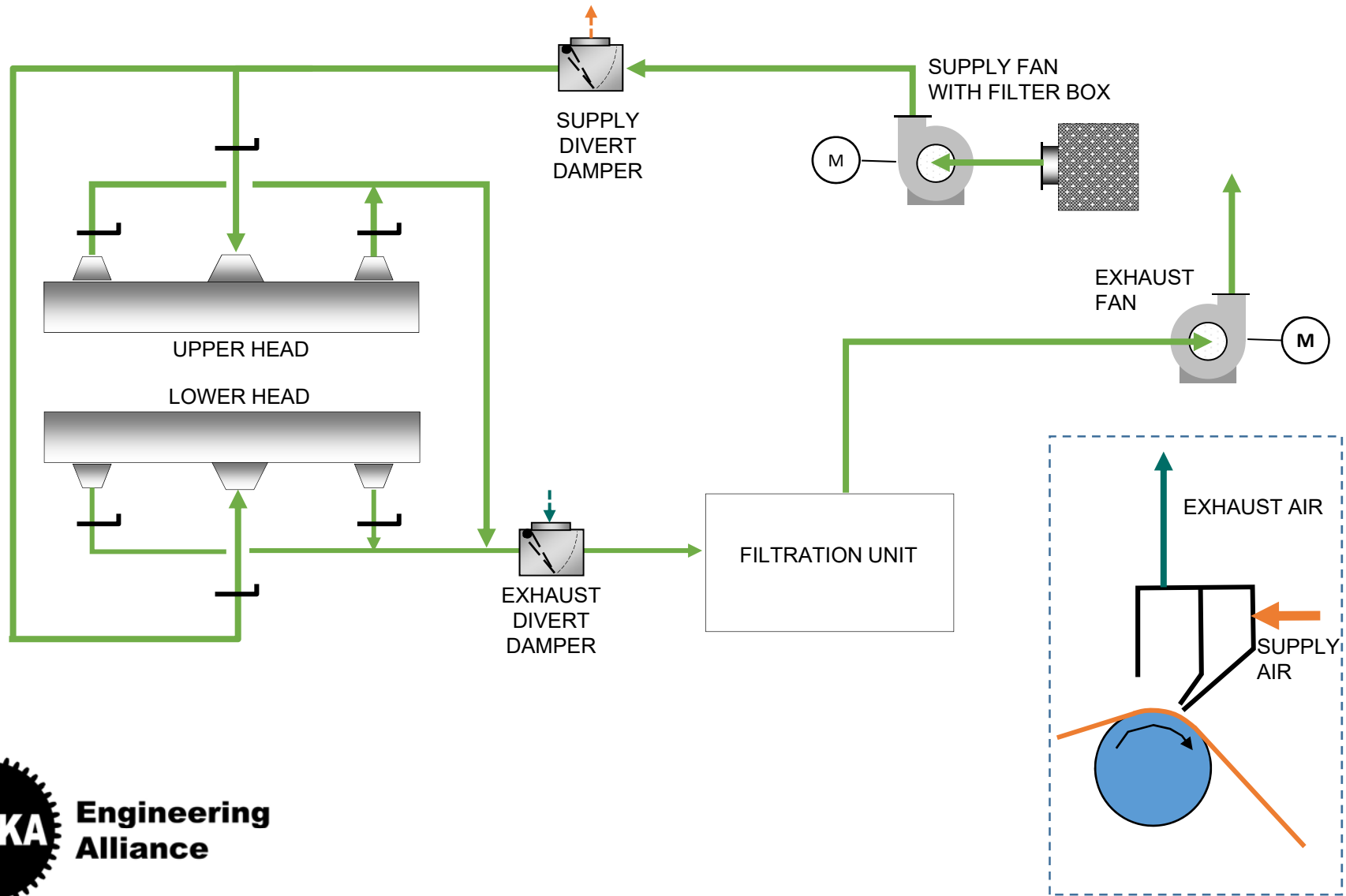

# WEB CLEANER SYSTEM – WITH WET SCRUBBER

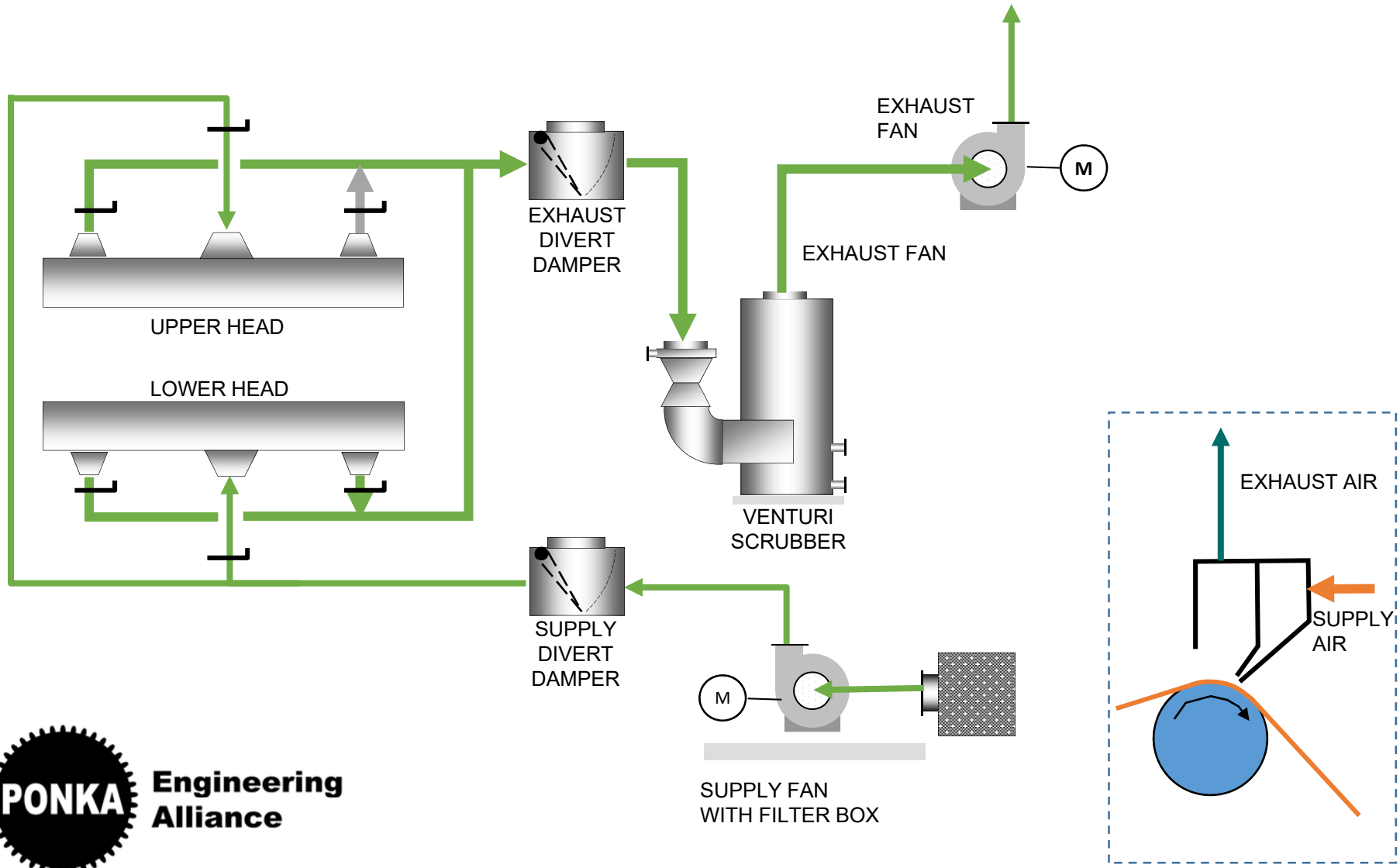

# TAIL THREADING REEL DRUM VACUUM

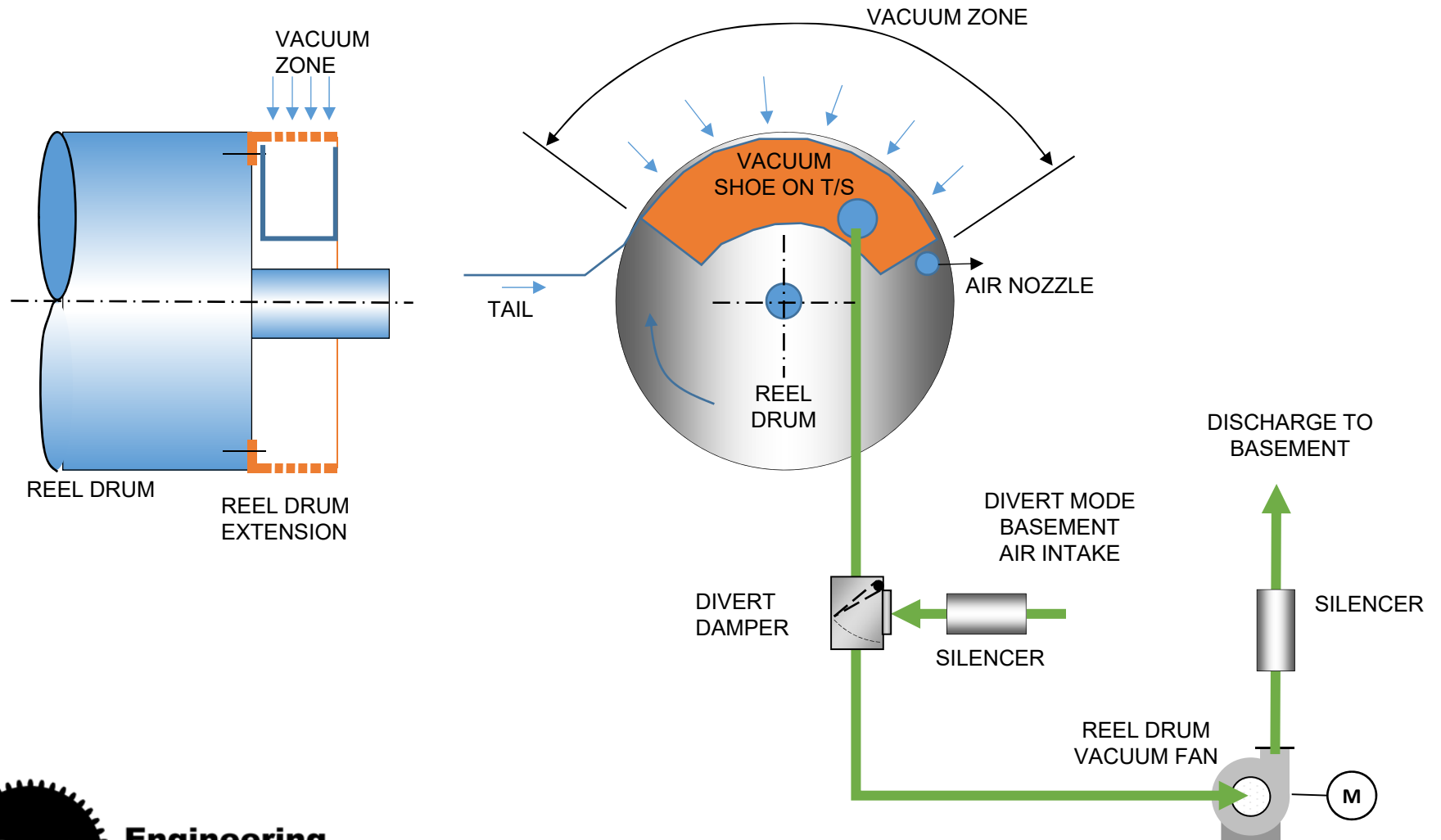

# TRIM CONVEYING SYSTEM – INJECTOR TYPE

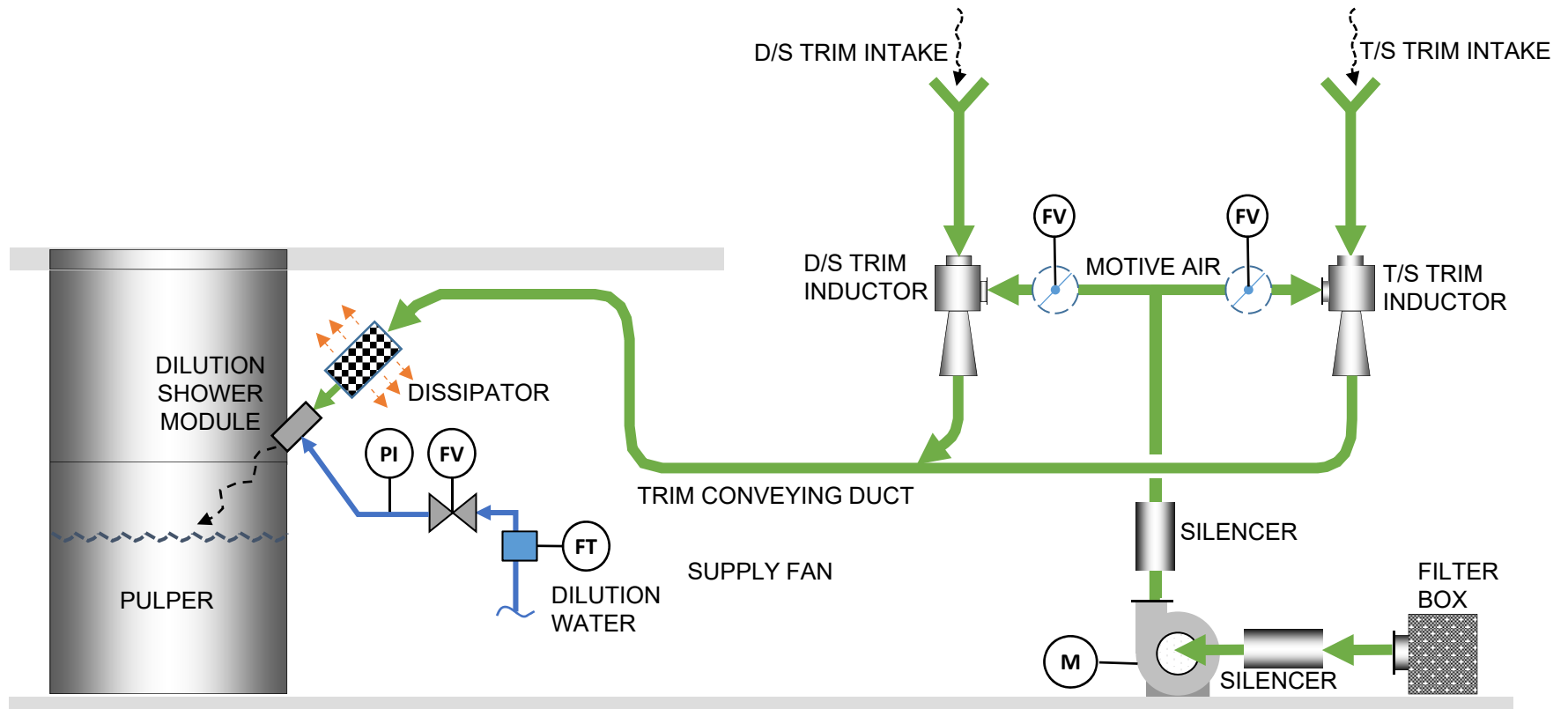

# TRIM CONVEYING SYSTEM – CHOPPER TYPE

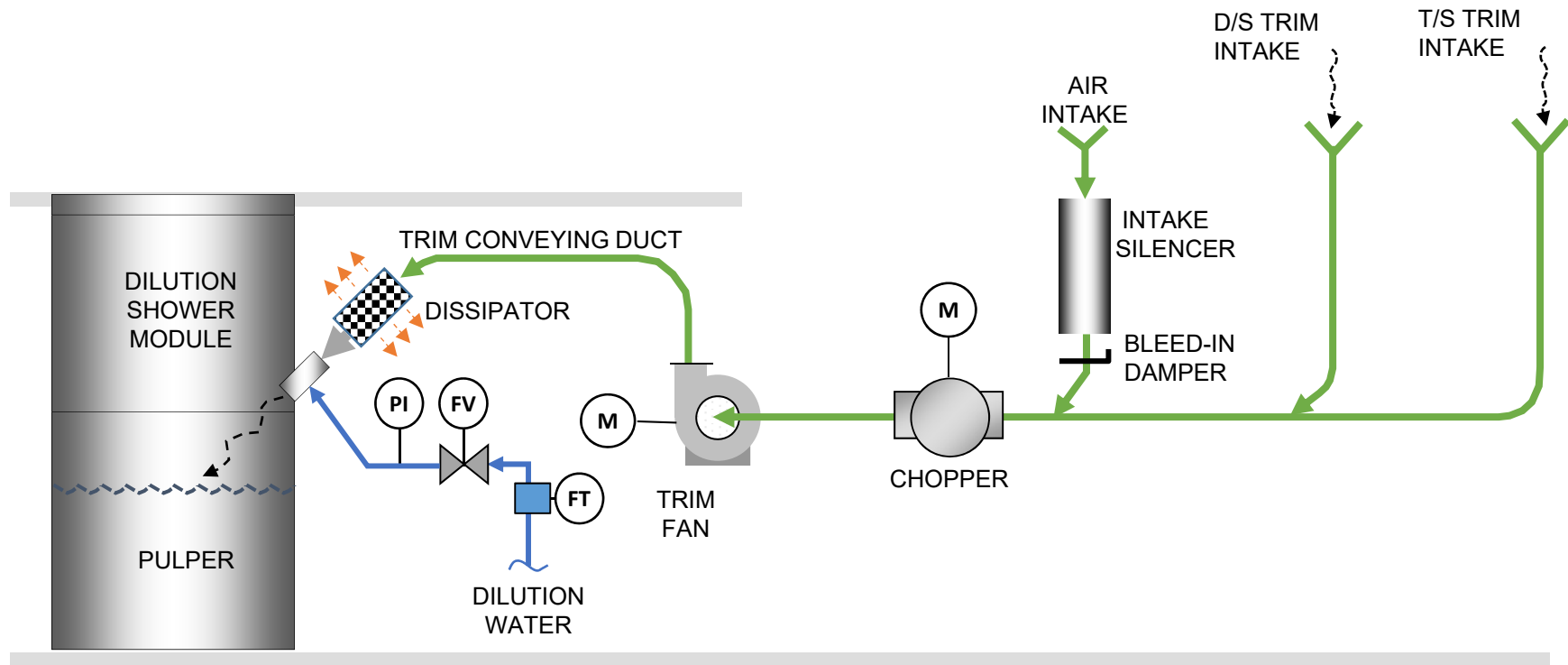

# TRIM CONVEYING SYSTEM – CHOPPER TYPE

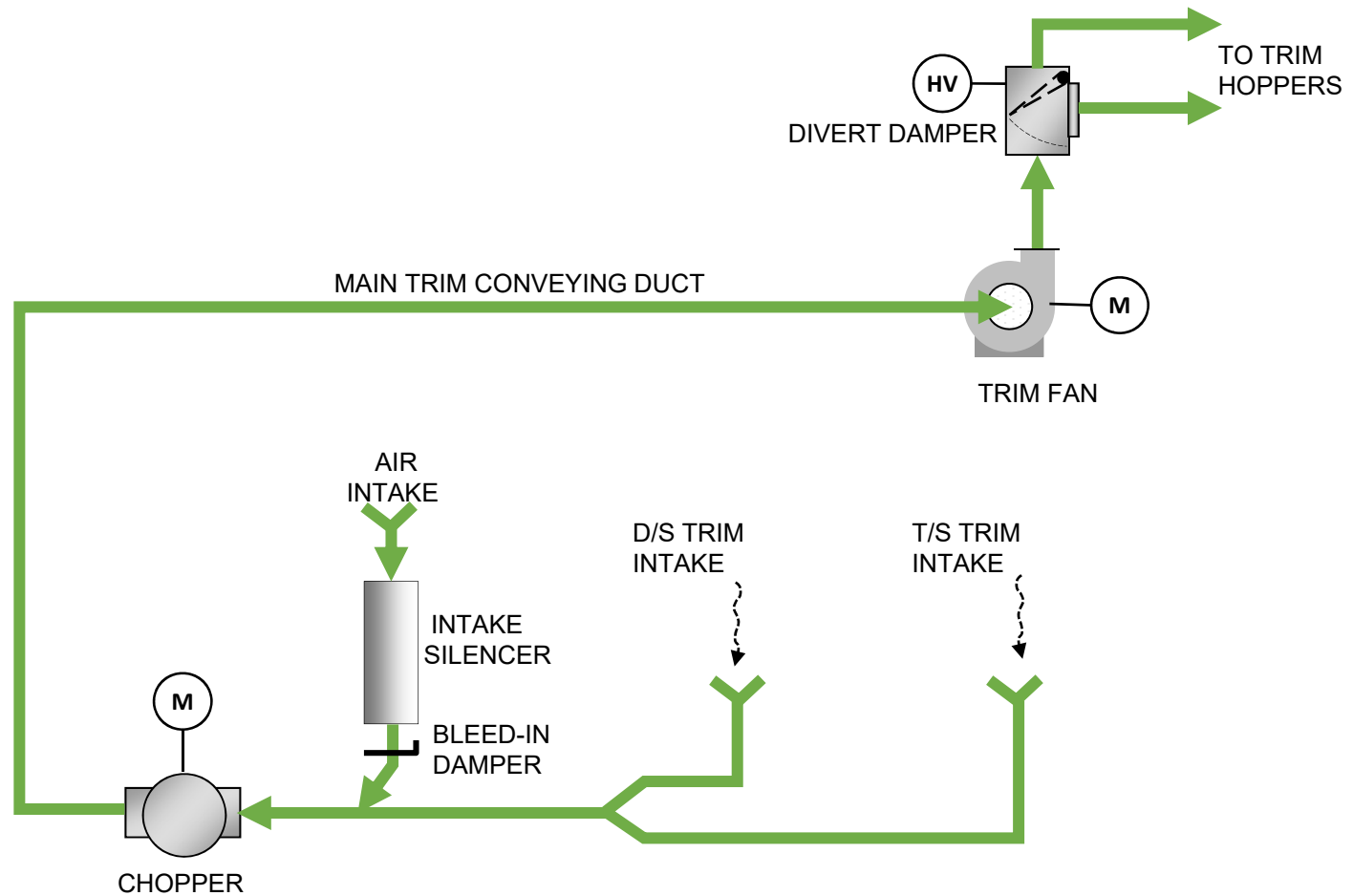



# TRIM CONVEYING SYSTEM – WET SEPARATOR TYPE

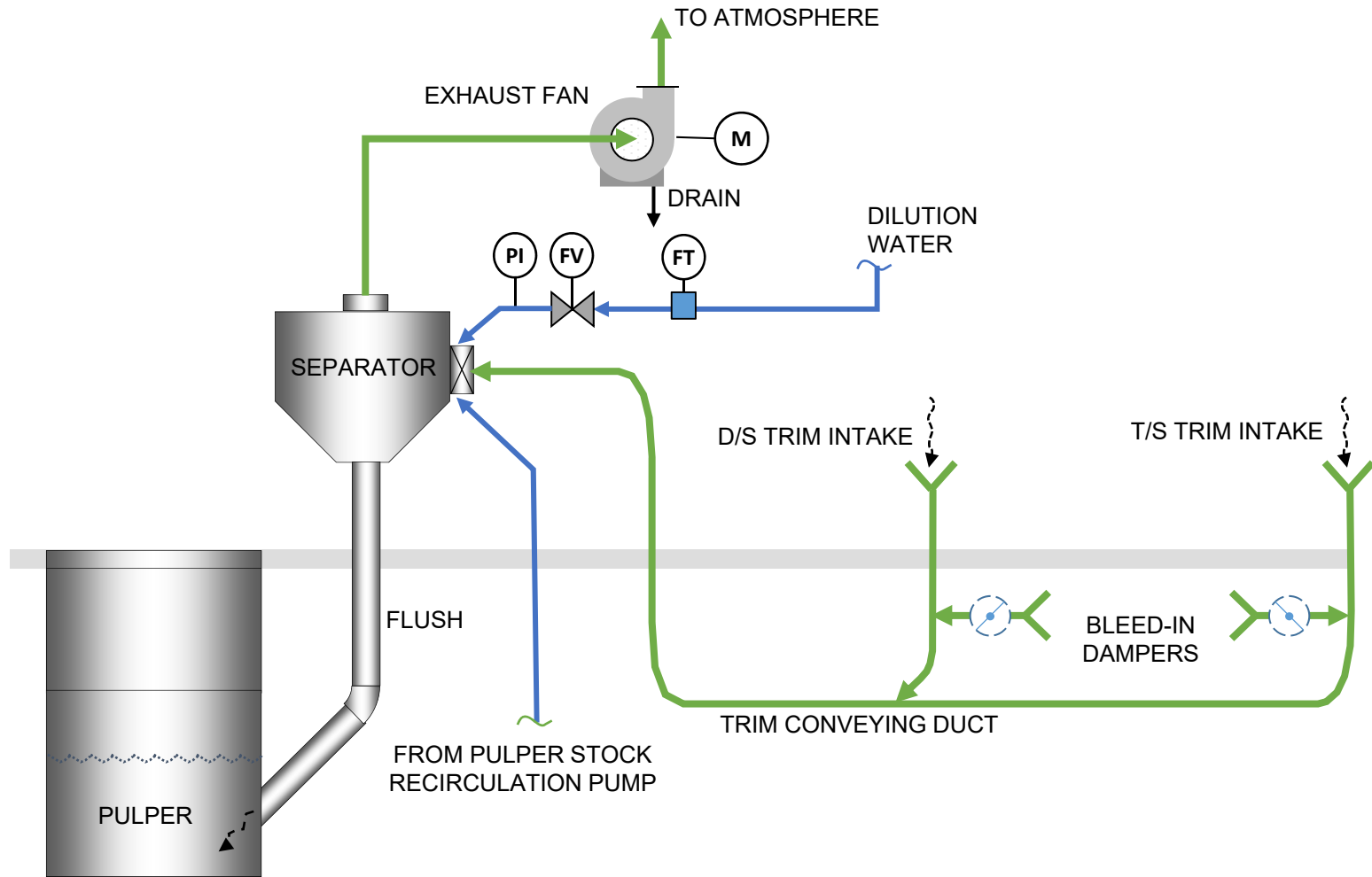

**Engineering Alliance**

# TRIM CONVEYING SYSTEM – WET SYSTEM

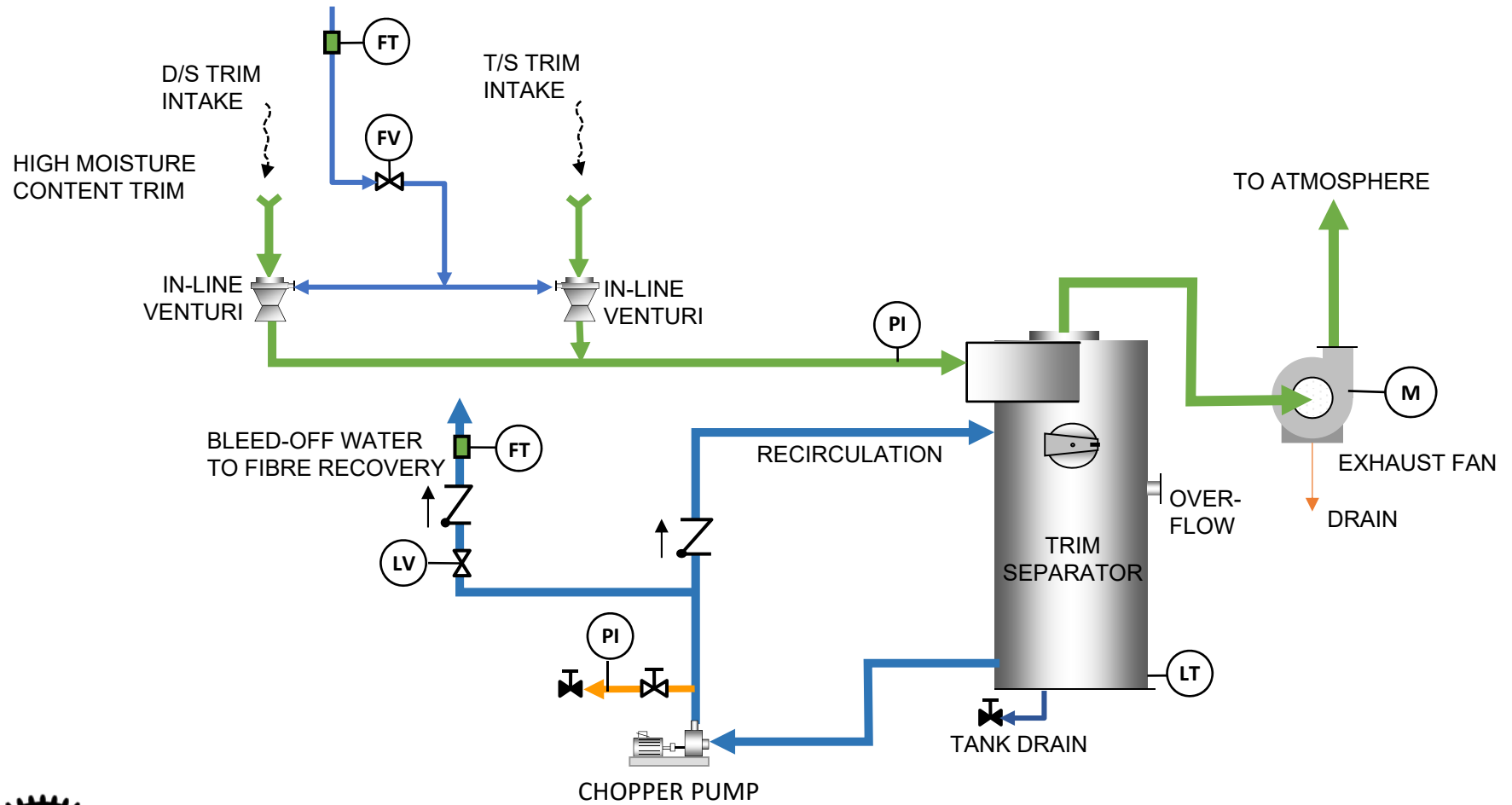

# AIR CURTAIN SUPPLY SYSTEM

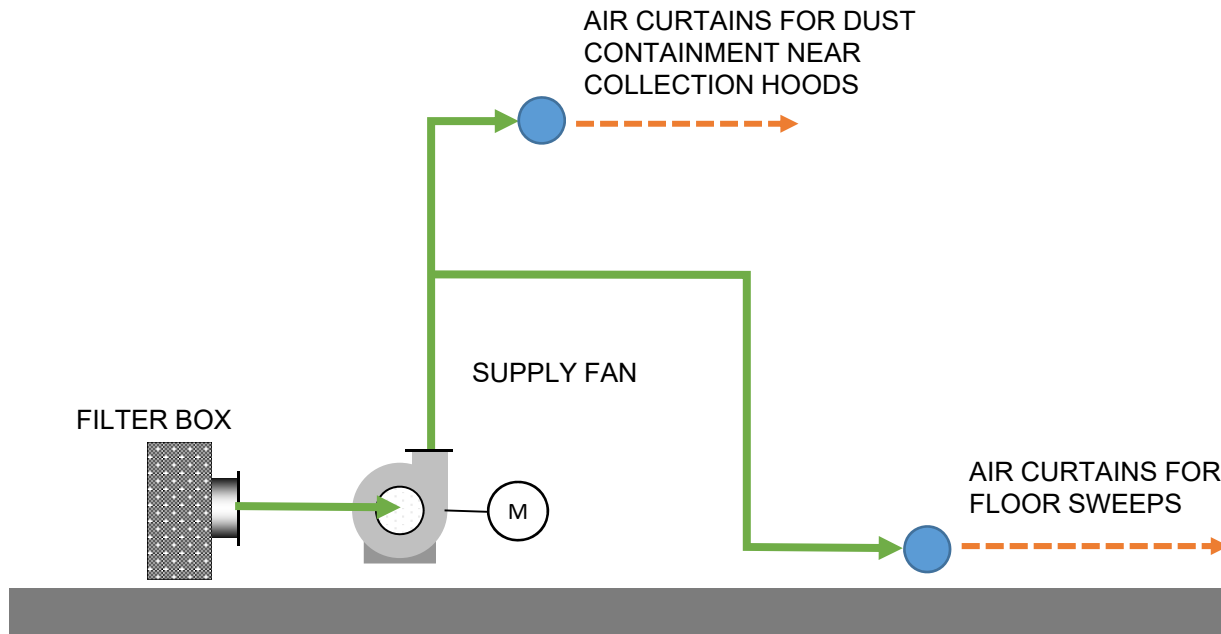

# TRUCK DOOR AIR CURTAINS

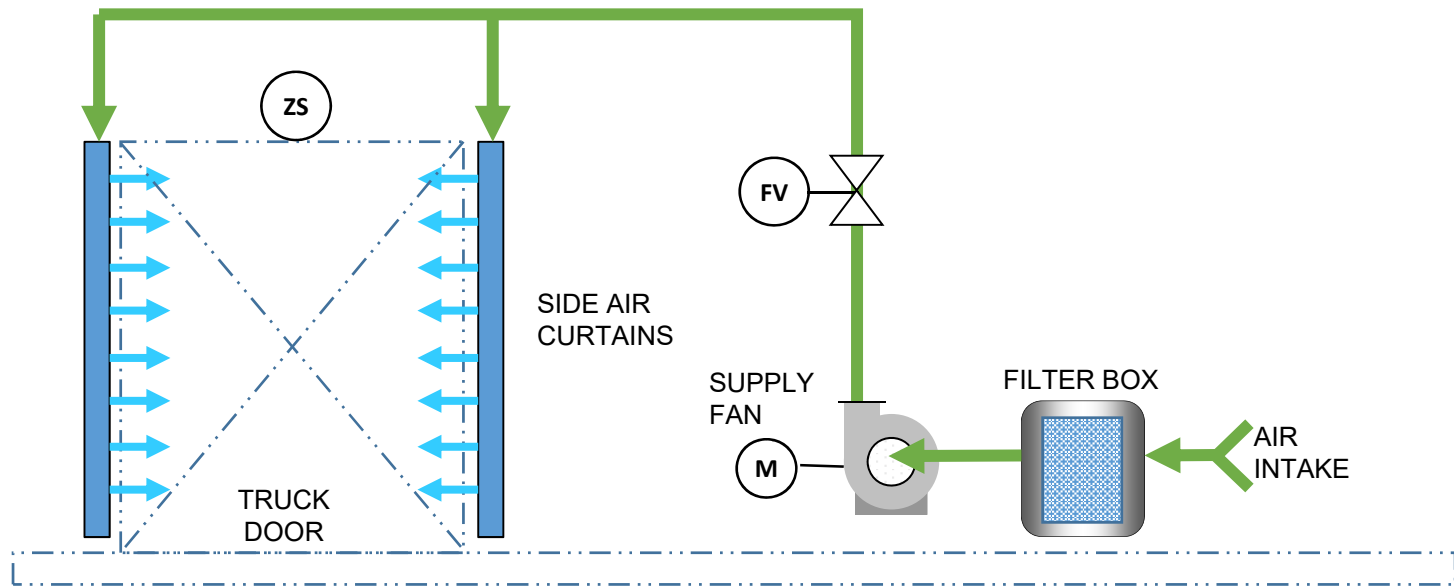

# PNEUMATIC FEED SYSTEM

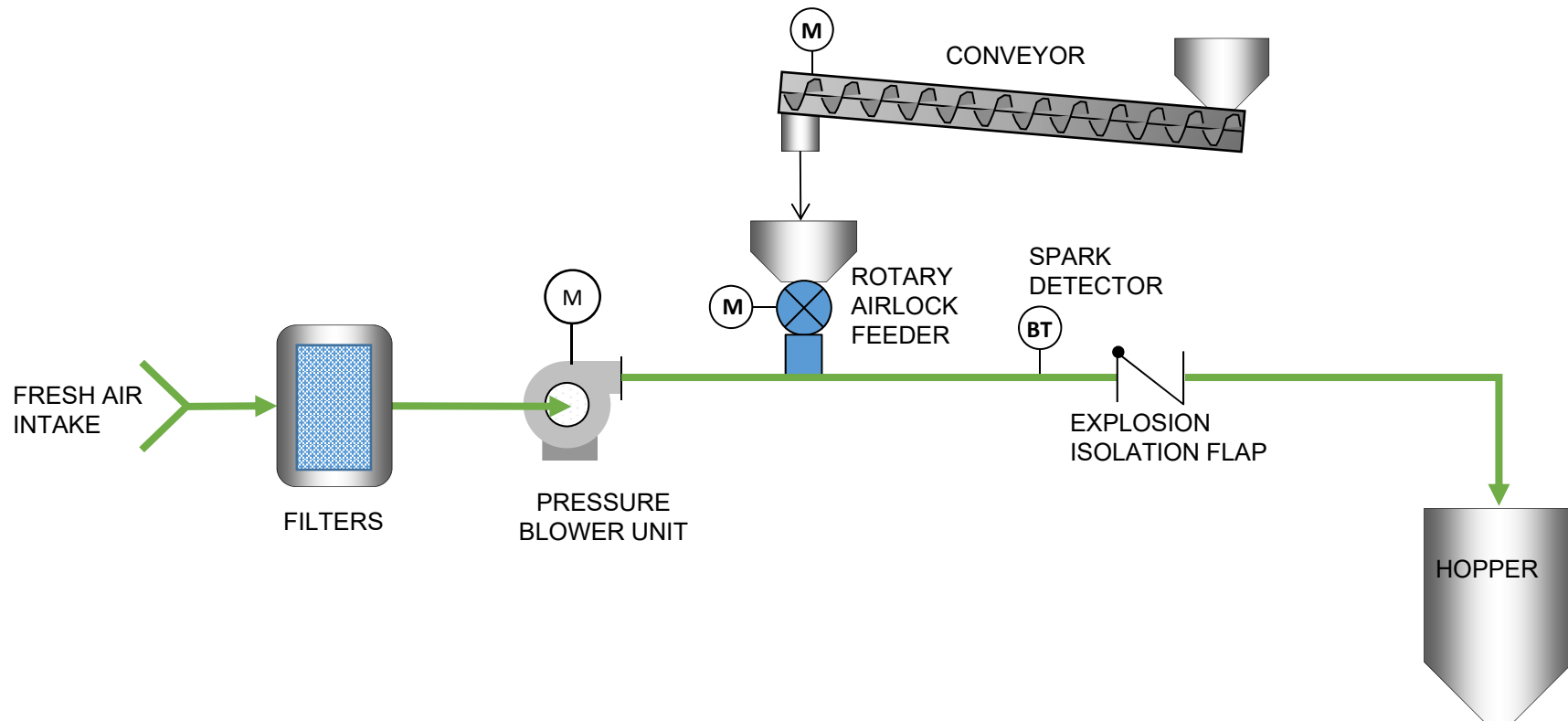

# SOLIDS CONVEYING SYSTEM

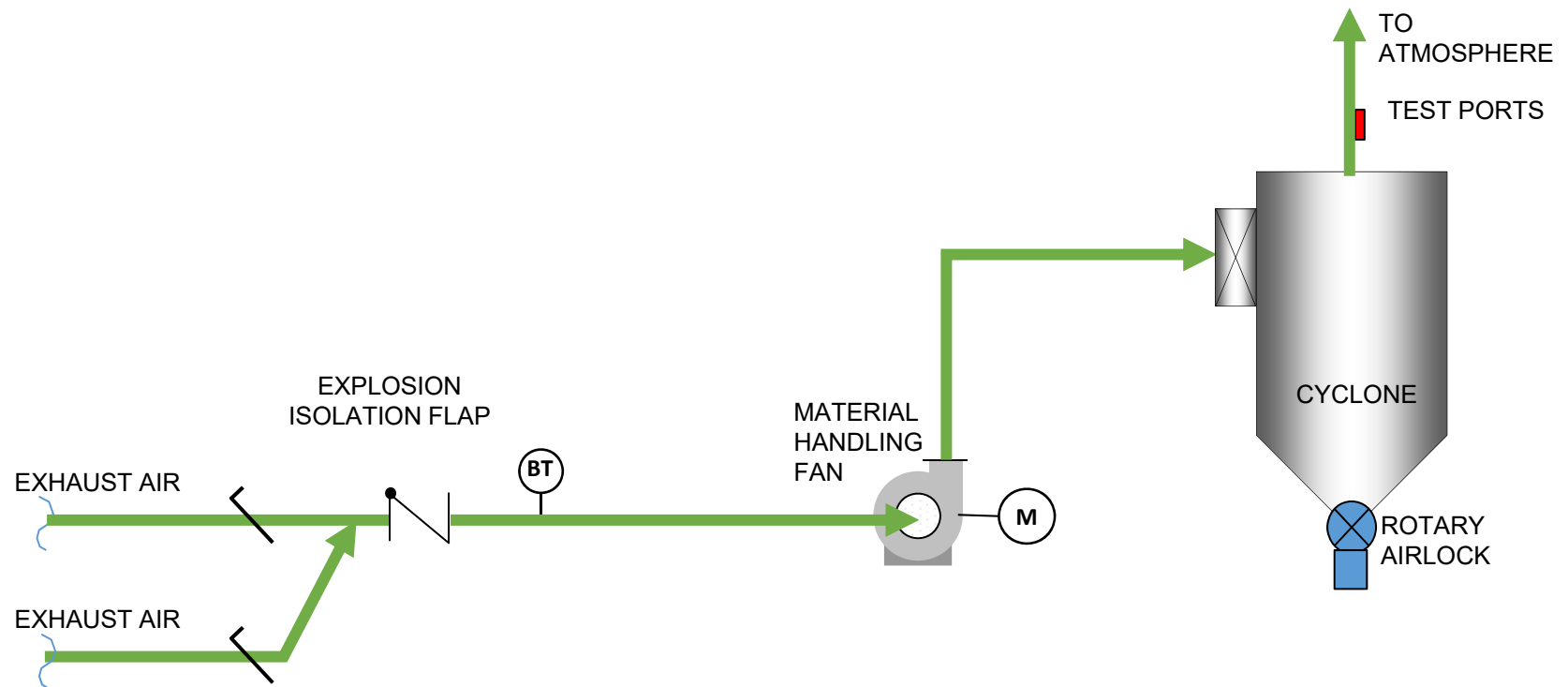

# BAGHOUSE SYSTEM

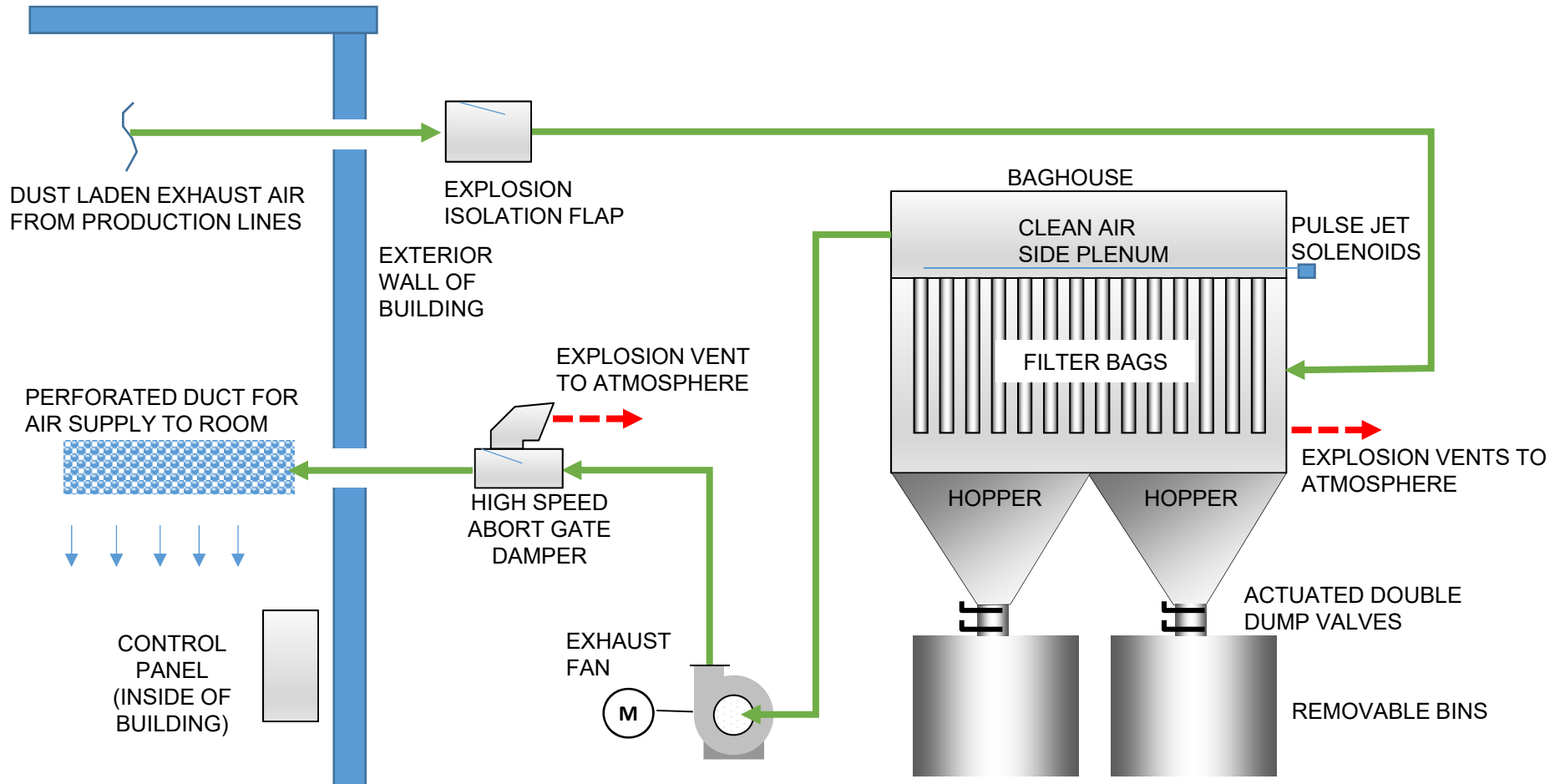

# CYCLONE AND BAGHOUSE SYSTEMS

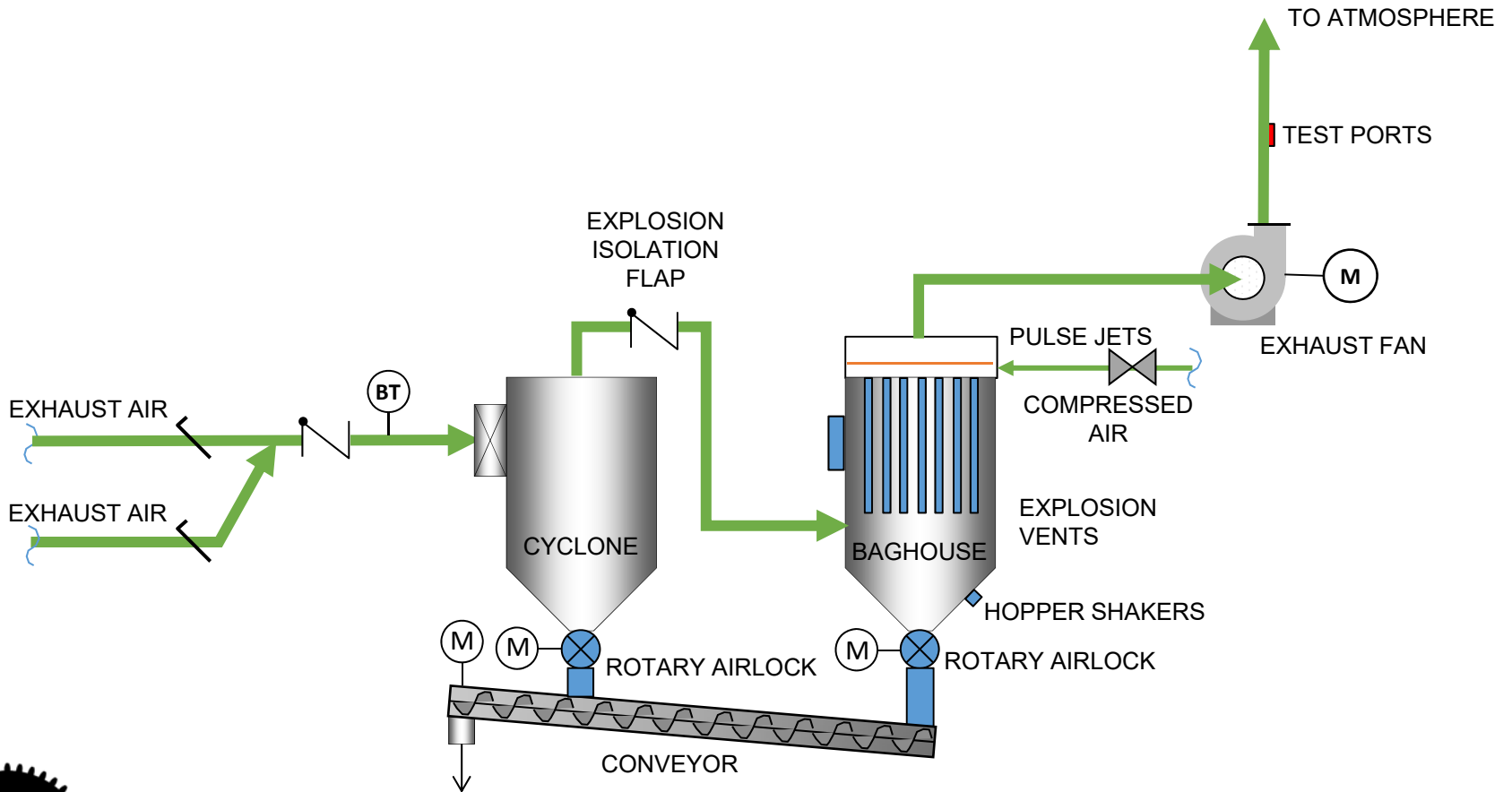



# TISSUE PNEUMATIC CONVEYING SYSTEMS

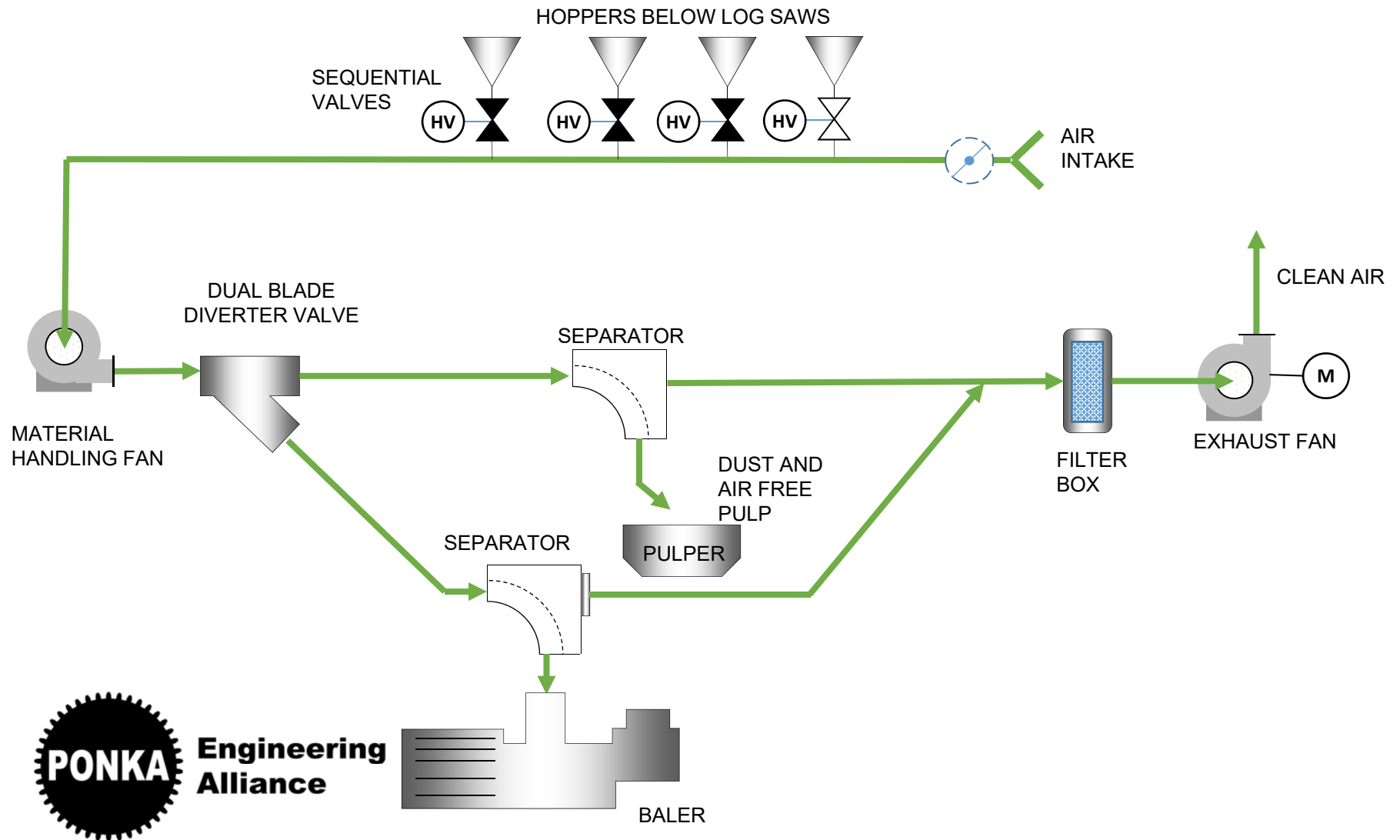

**Engineering Alliance**

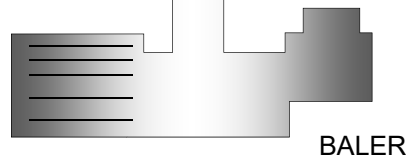

BALER

# INDUSTRIAL VACUUM SYSTEM

