

ROUND INSPECTION PORT

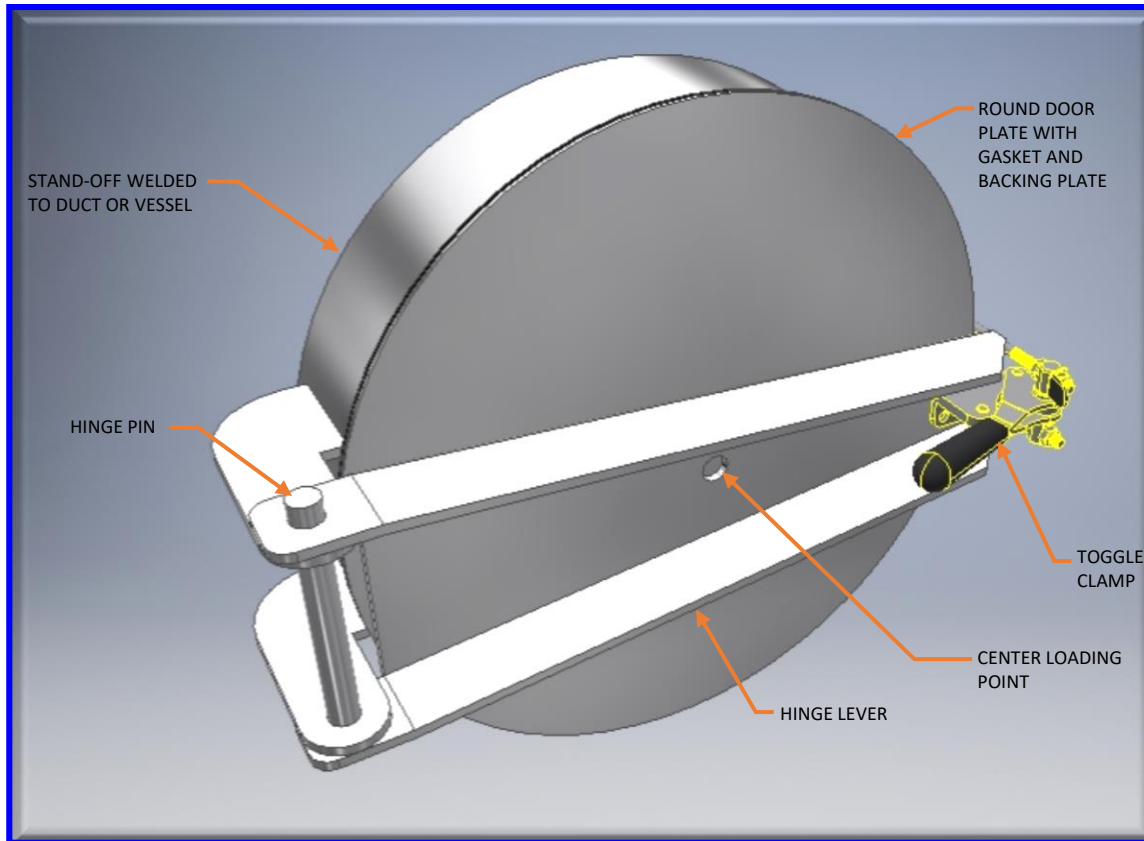

Application:

- Suitable for mounting on ducting or equipment for various wet ventilation systems
- Standard sizes: 12"Ø, 18"Ø, 24"Ø
- Working pressure: up to 40 inWC

Features:

- Gasket (neoprene, EPDM, or silicone)
- Tight-sealing, center-loading door plate
- Hinged lever with heavy-duty toggle clamp
- Available in stainless steels or painted carbon steel

Benefits:

- Simple, reliable, and easy to maintain
- Heavy-duty construction

How it works:

- The door is loaded at it's center
- The gasket is loaded evenly on the perimeter of the door to achieve a watertight seal



**Engineering
Alliance**