

# ANGLED SLIDE GATE DAMPER

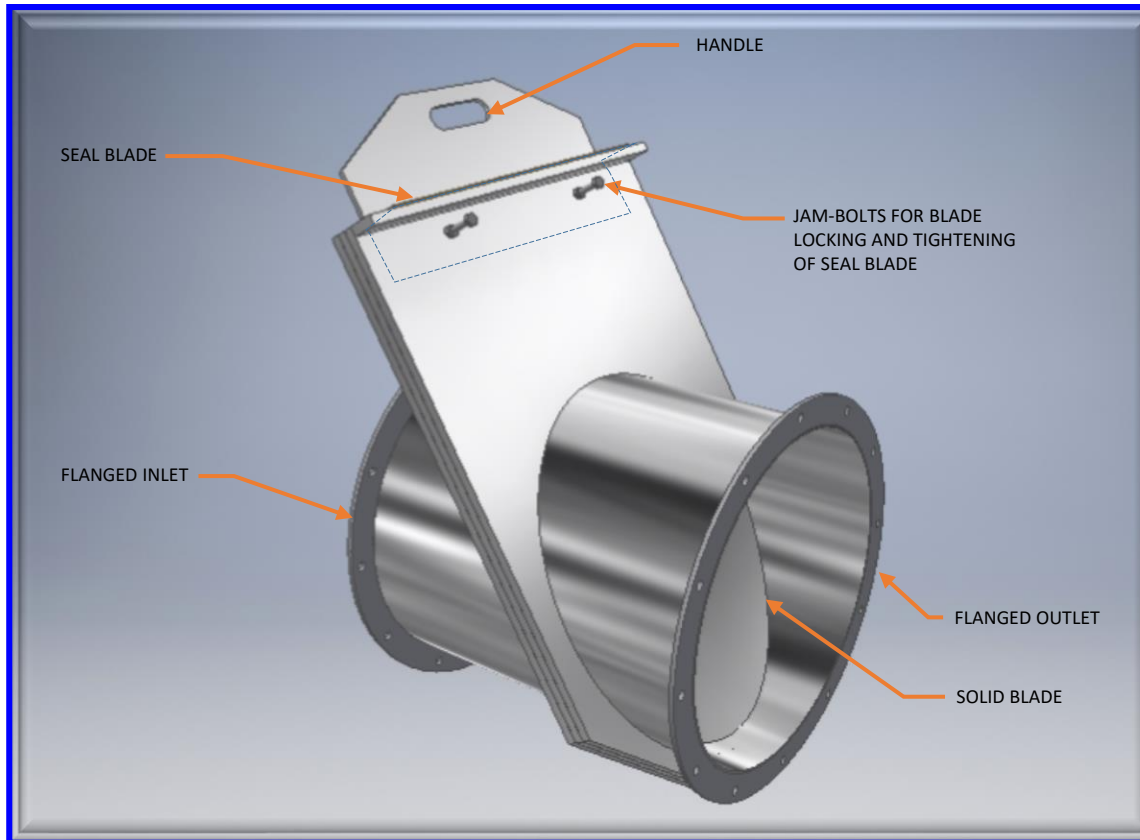

## Application:

- Suitable for dust and material conveying systems
- Use for tight shut-off or balancing of dust or material conveying airstreams
- Sizes ranging from 8" to 32" diameter
- Differential pressure: up to 30 inWC

## Features:

- Flanged inlet and outlet connections in short spool section
- Tight sealing positive-stop blade
- Seal blade and locking bolts
- Available in stainless steels or painted carbon steel

## Benefits:

- Duct can be disconnected on one side to leave branch isolated
- Angled blade is less susceptible to build-up of conveyed dust or materials
- Simple, reliable, and easy to maintain
- Heavy-duty construction



**Engineering  
Alliance**