

ROUND SLIDE GATE DAMPER

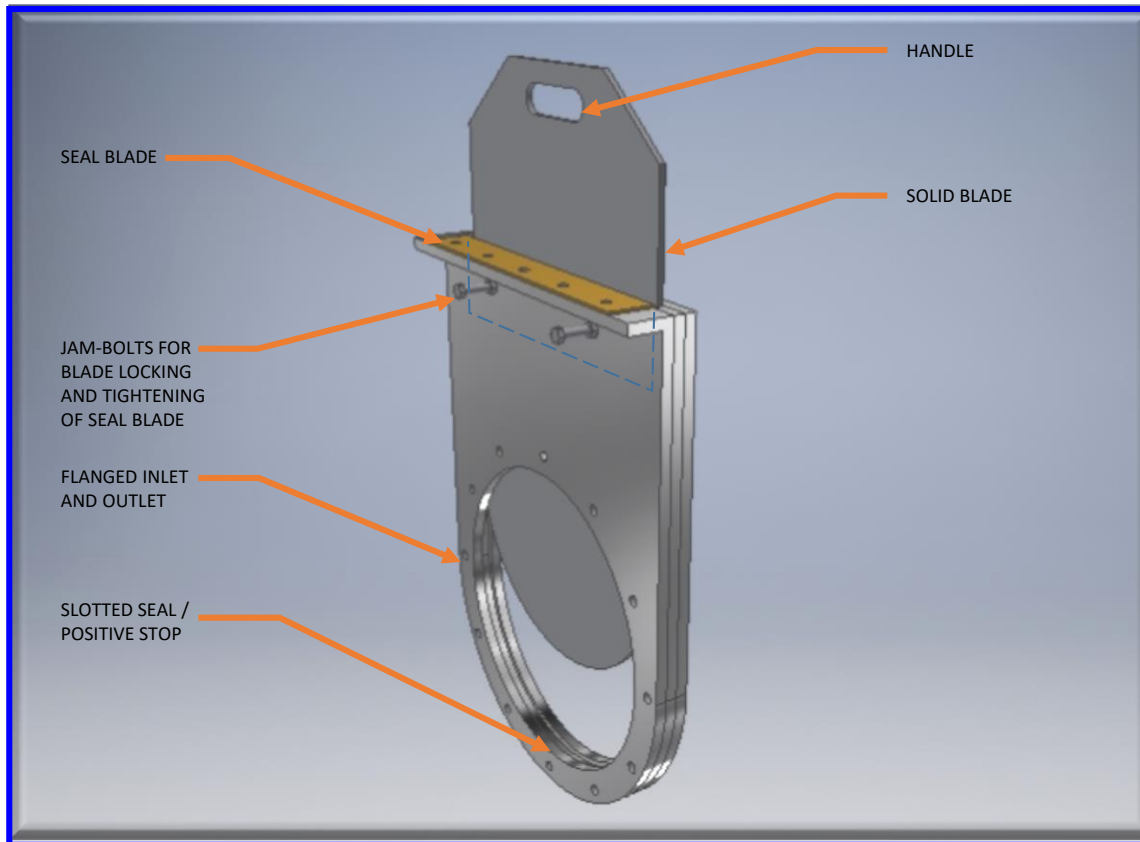

Application:

- Use for tight shut-off or balancing of an airstream
- Use for open/close flow control in material handling systems
- Sizes ranging from 8" to 56" diameter
- Up to 50 inWC

Features:

- Flanged inlet and outlet connections with tapped holes
- Tight-sealing, positive-stop, polished blade,
- Seal blade with locking bolts
- Can be fitted with optional jack-screw, manual lever, or pneumatic actuator
- Available in stainless steels or painted carbon steel

Benefits:

- Short flange to flange connection
- Duct can be disconnected on one side to leave branch isolated
- Simple, reliable, and easy to maintain
- Heavy-duty construction



**Engineering
Alliance**