

RECTANGULAR MULTI-BLADE DAMPER

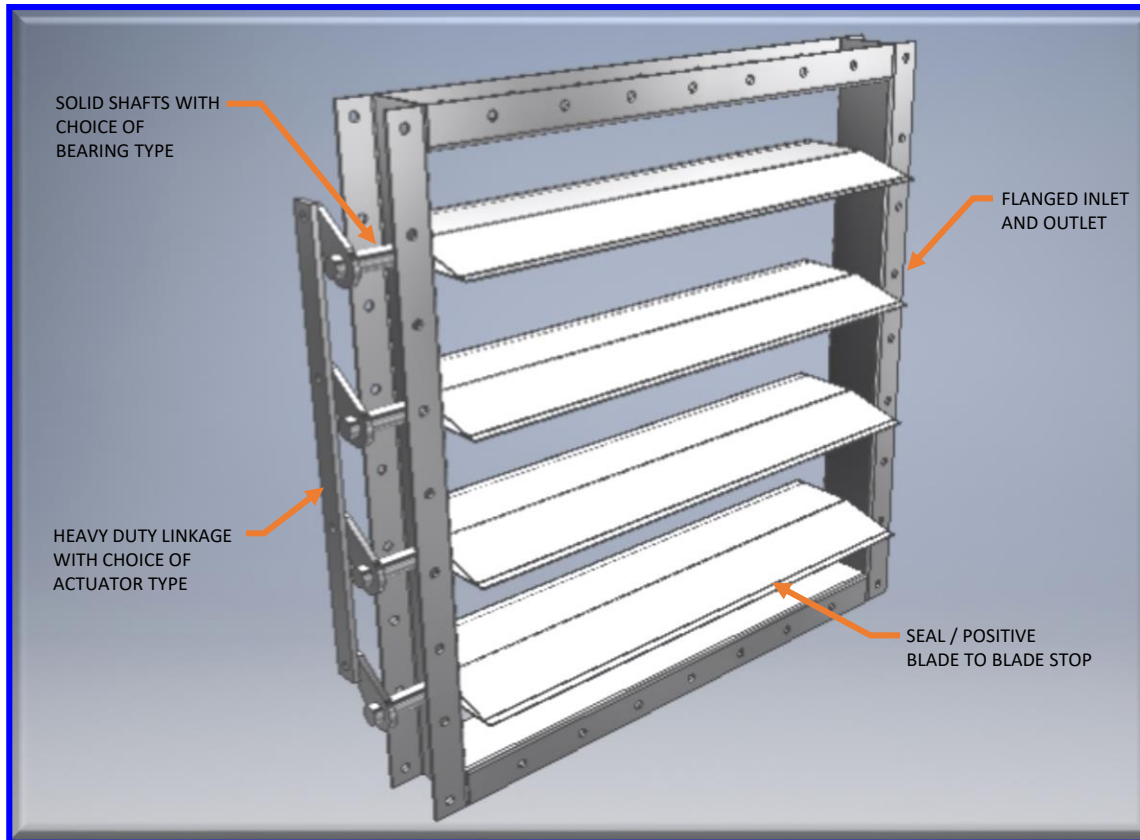

Application:

- Use for tight shut-off or balancing of an airstream with a rectangular duct
- Sizes ranging from 36" to 132" horizontal dimension
- Differential pressure: up to 30 inWC

Features:

- Flanged inlet and outlet connections
- Tight sealing positive-stop blades
- Can be fitted with manual locking quadrant, gear box with chain wheel, or positioned cylinder-lever actuator
- Can be fitted with anti-friction bearings or plain bearings with packing for high temperature applications
- Available in stainless steels or painted carbon steel

Benefits:

- Simple, reliable, and easy to maintain
- Heavy-duty construction



**Engineering
Alliance**